

CAUTION - READ MANUAL & ALL NOTES BEFORE INSTALLING OR OPERATING CONTROL. SEE NOTE 1.
NO CIRCUIT CALIBRATION OR ADJUSTMENT EVER REQUIRED.

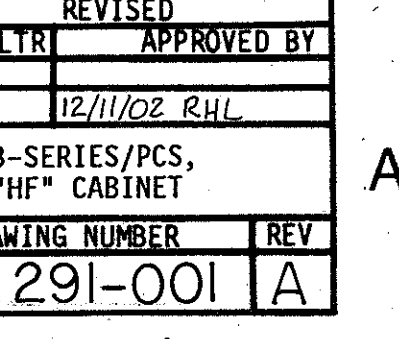
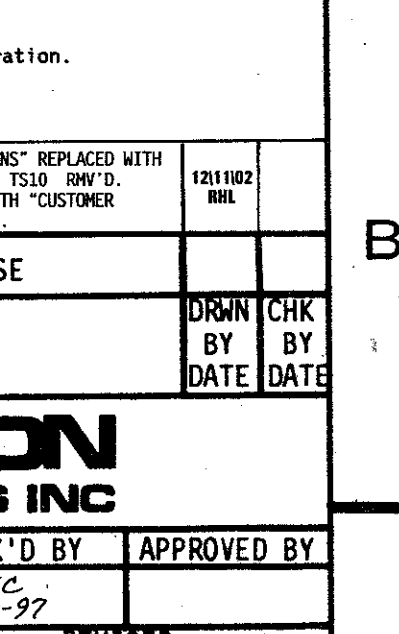
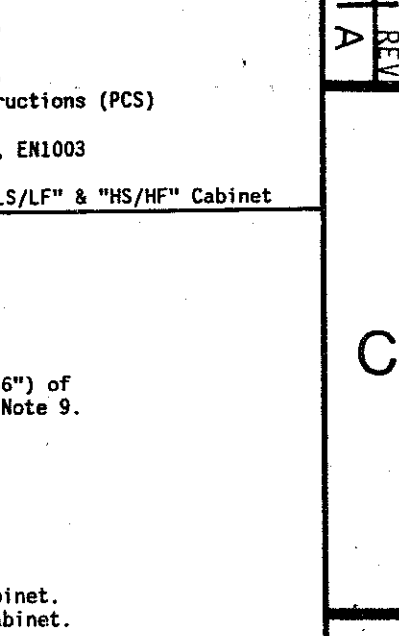
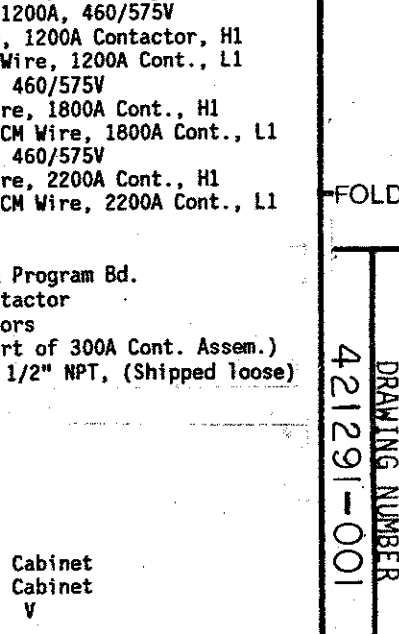
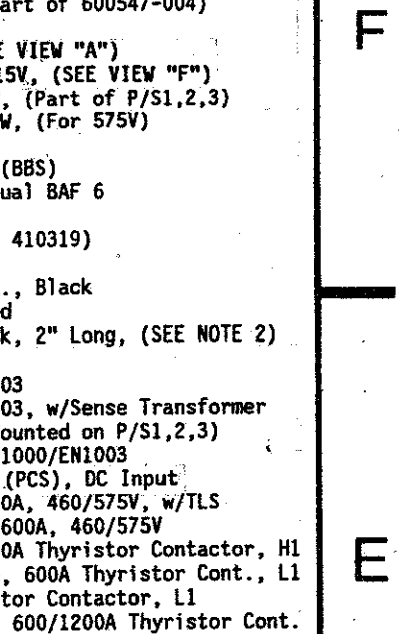
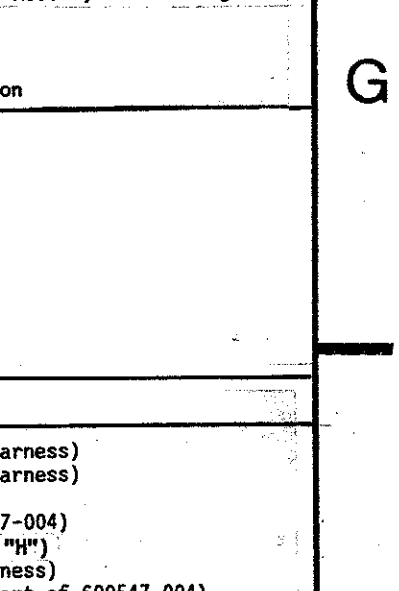
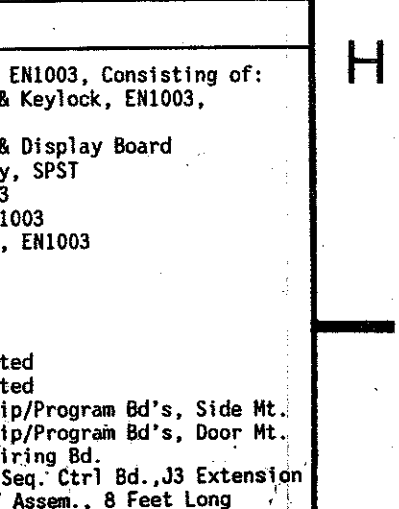
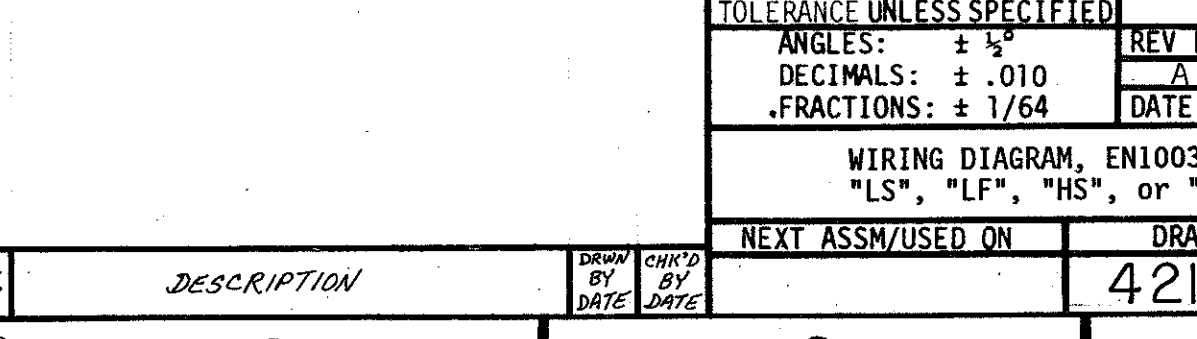
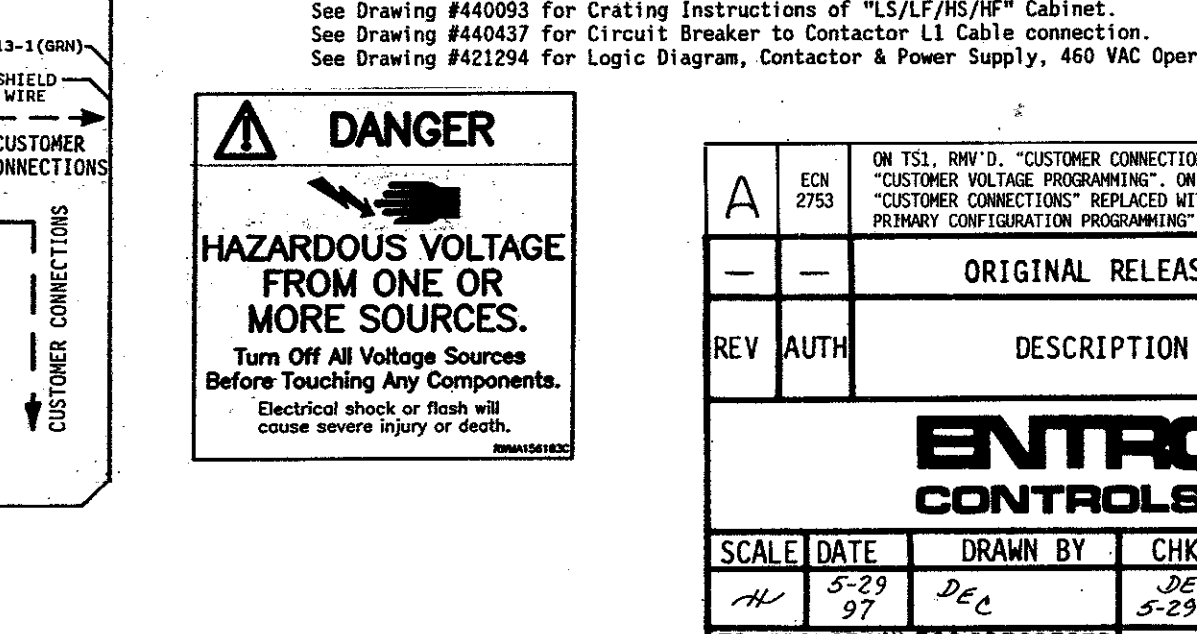
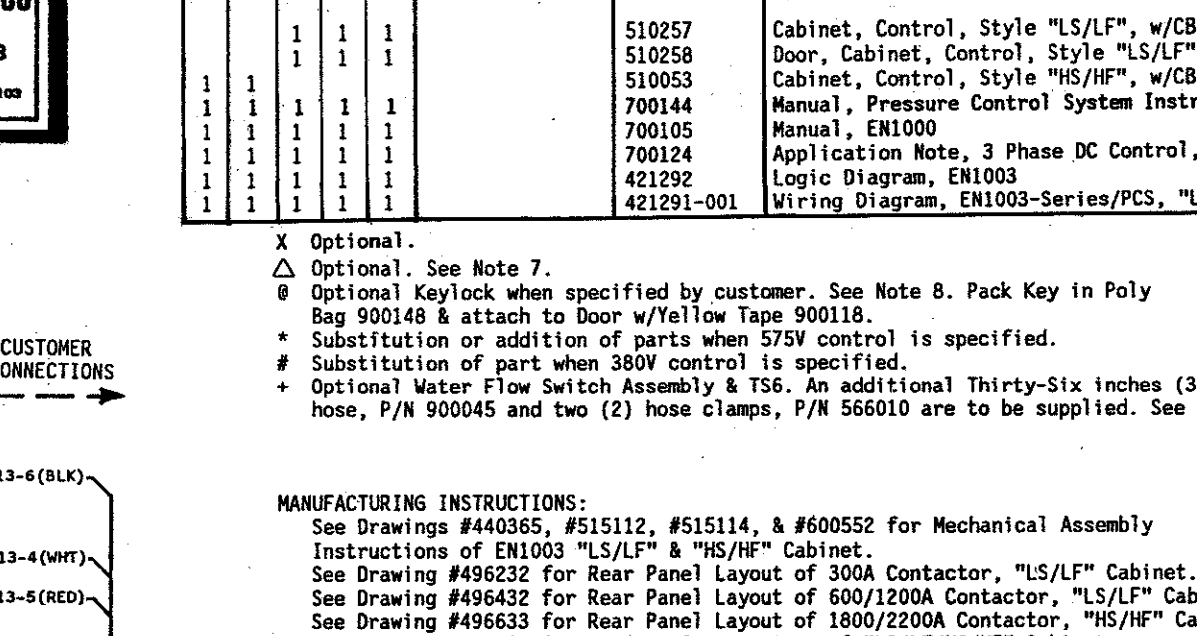
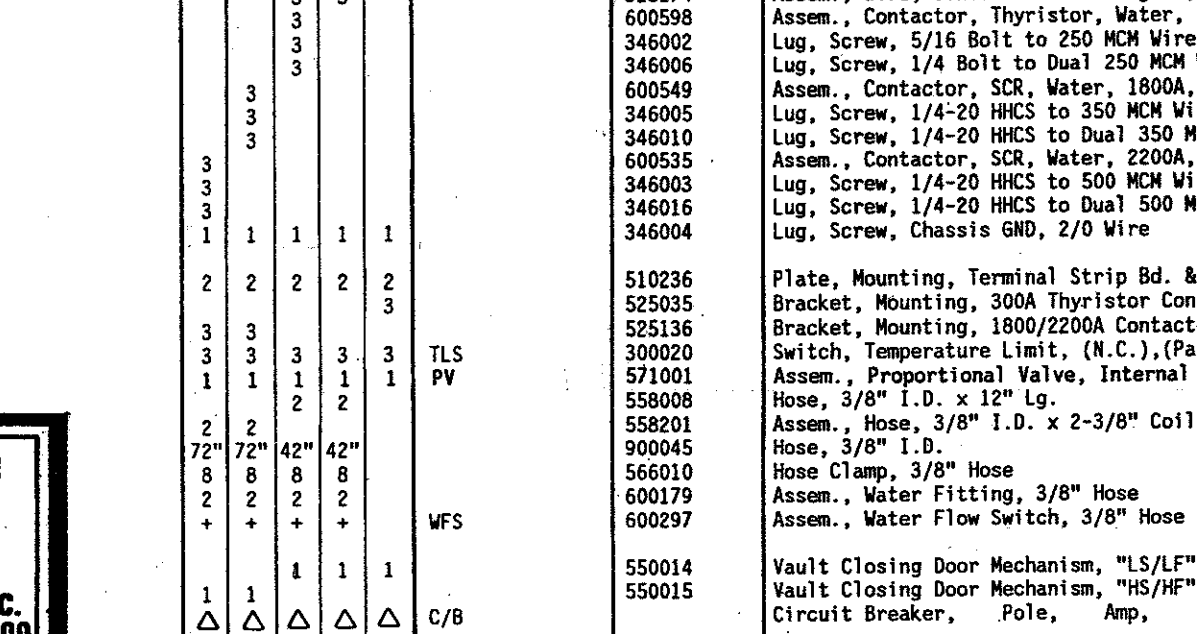
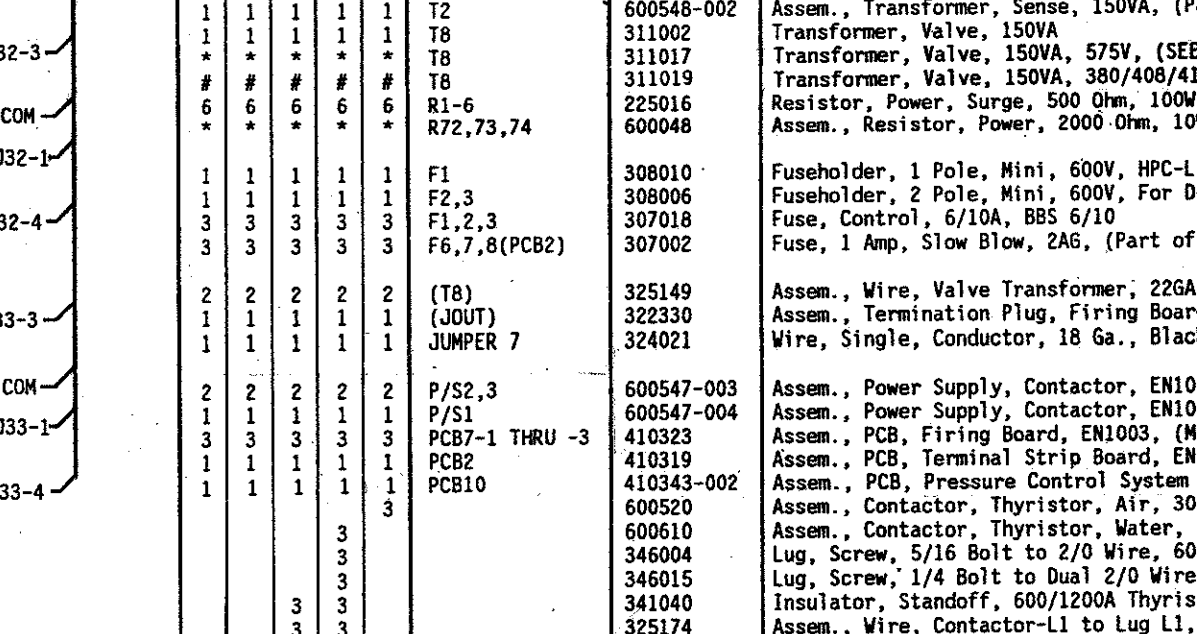
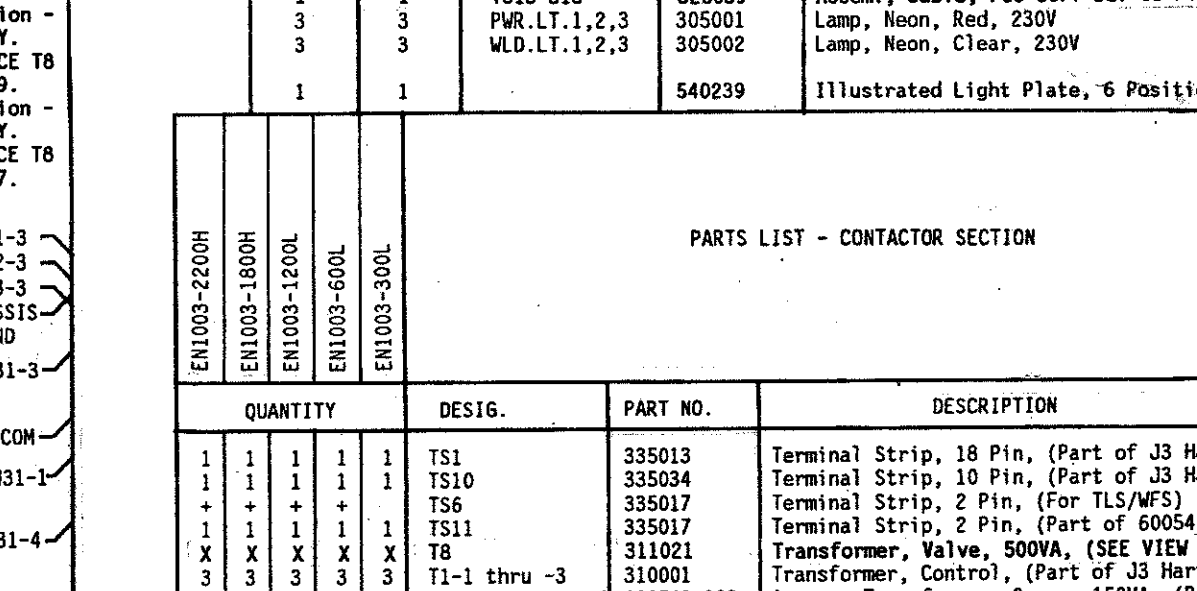
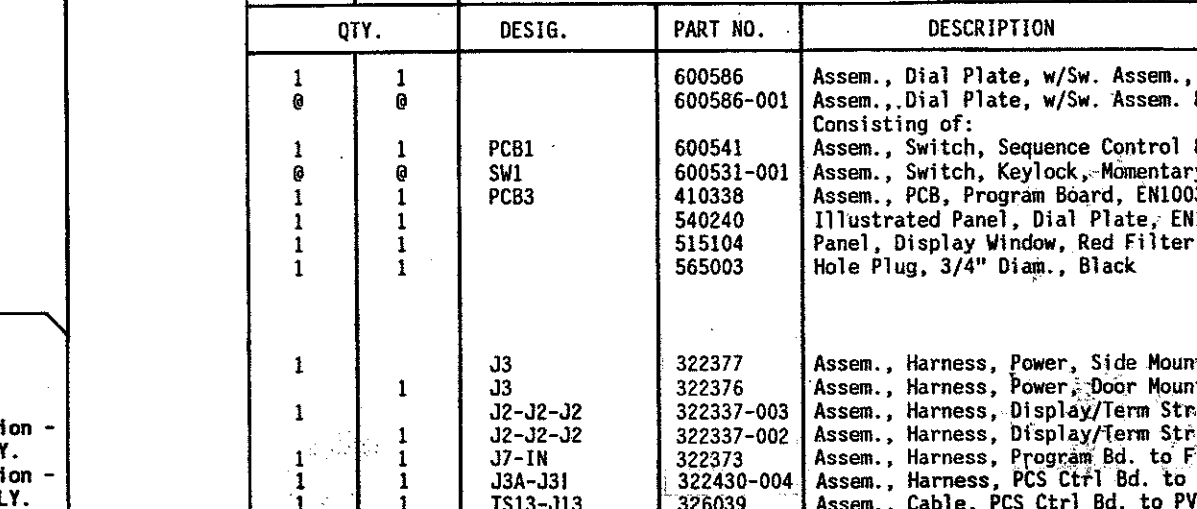
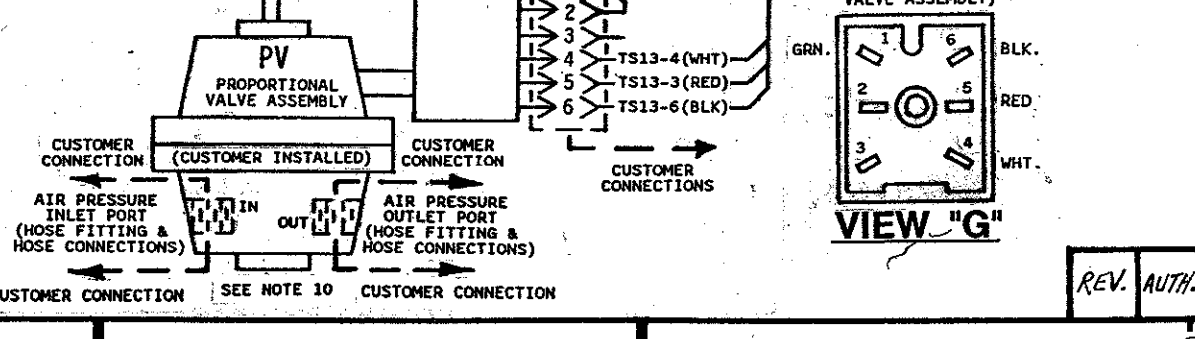
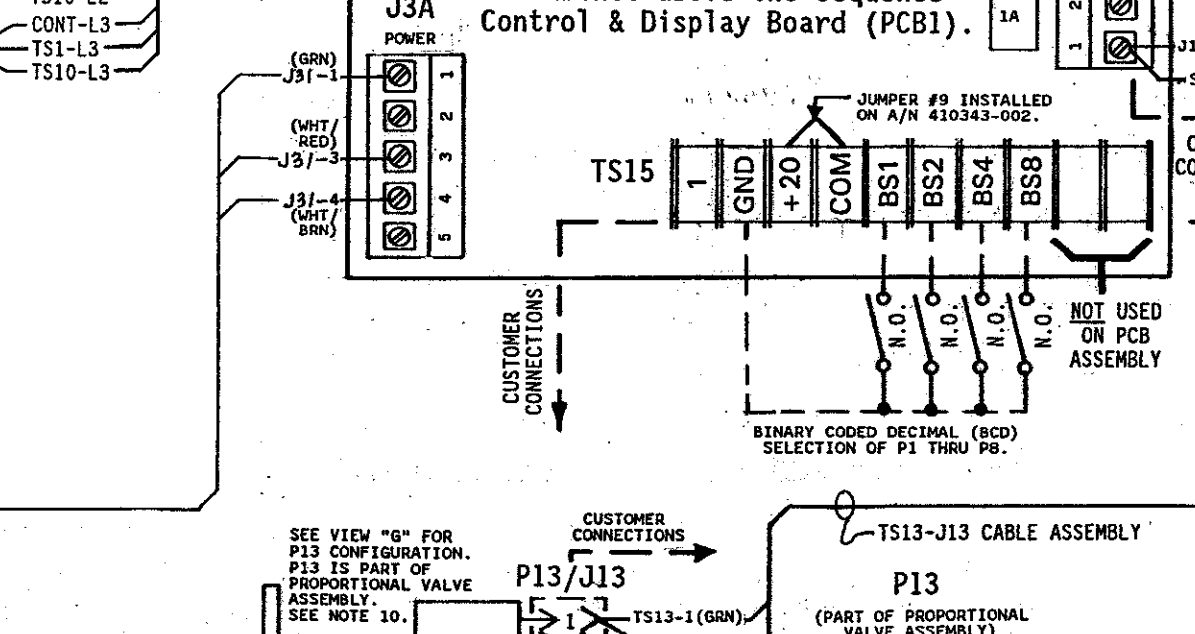
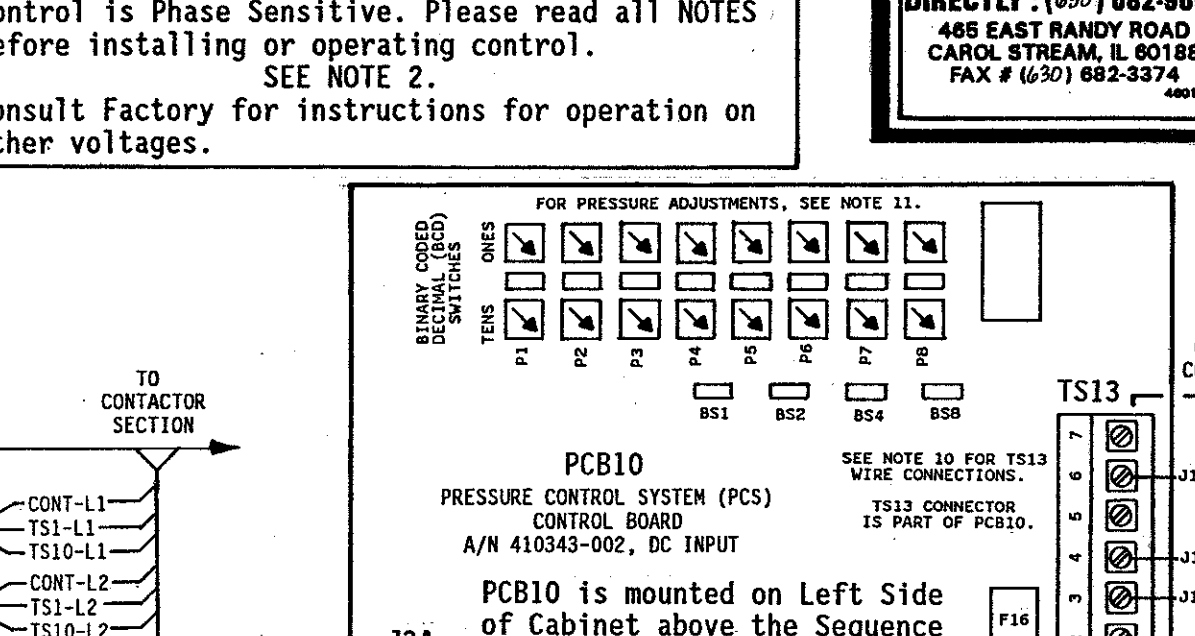
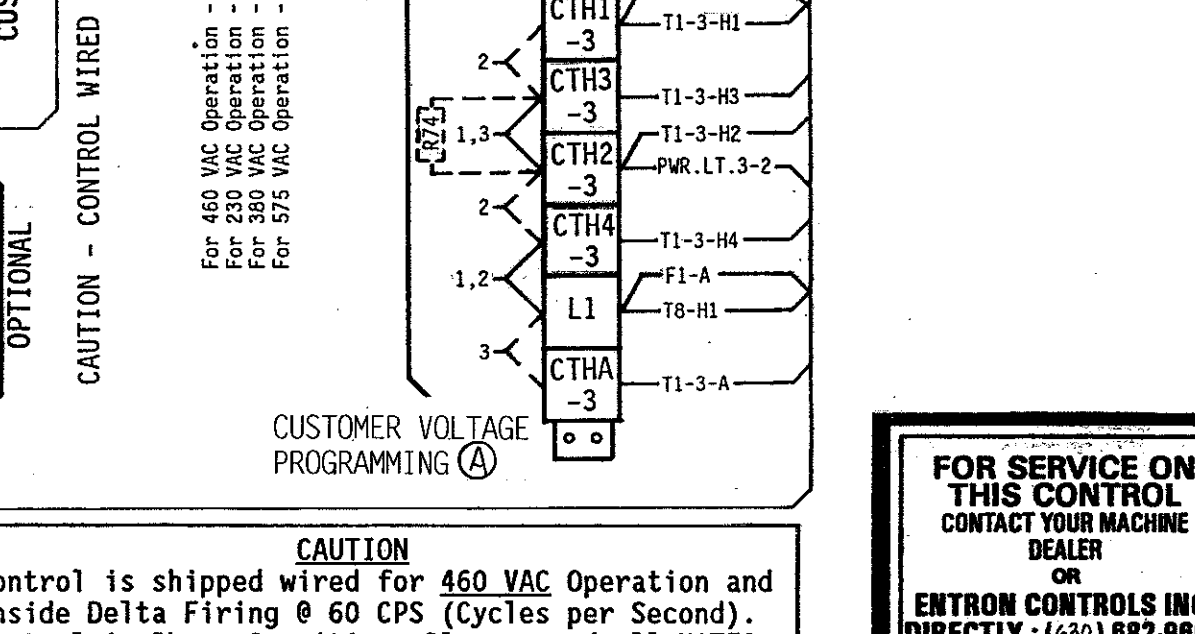
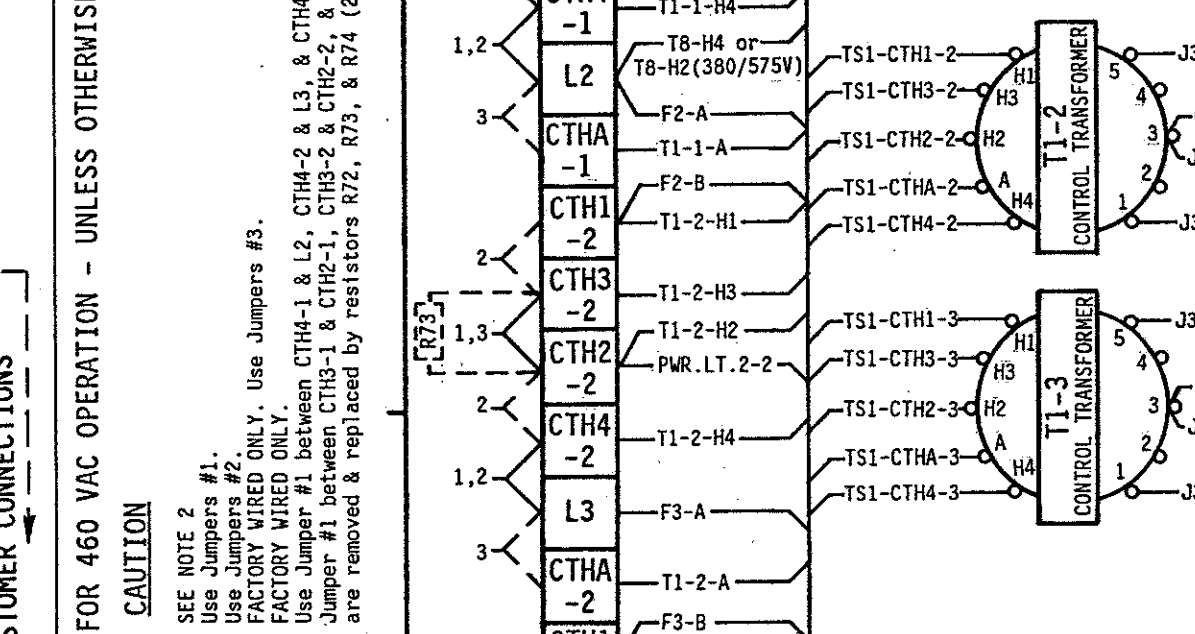
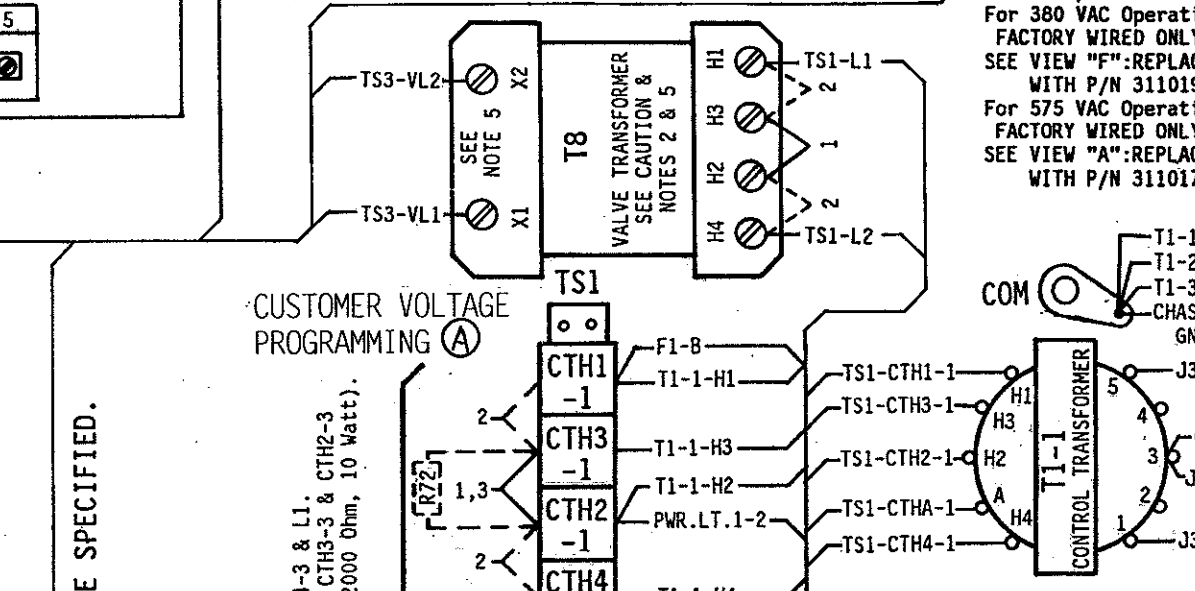
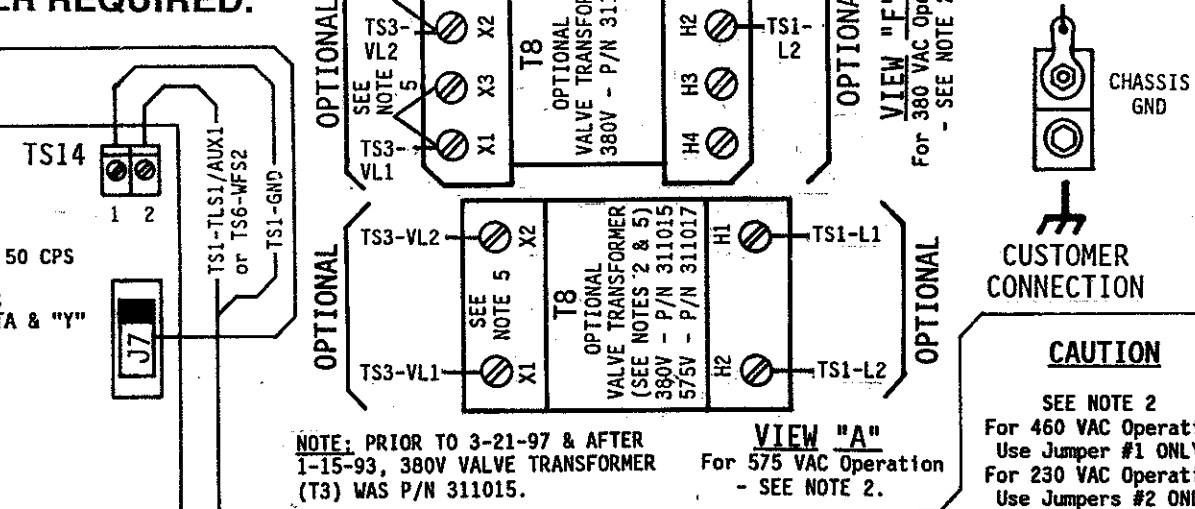
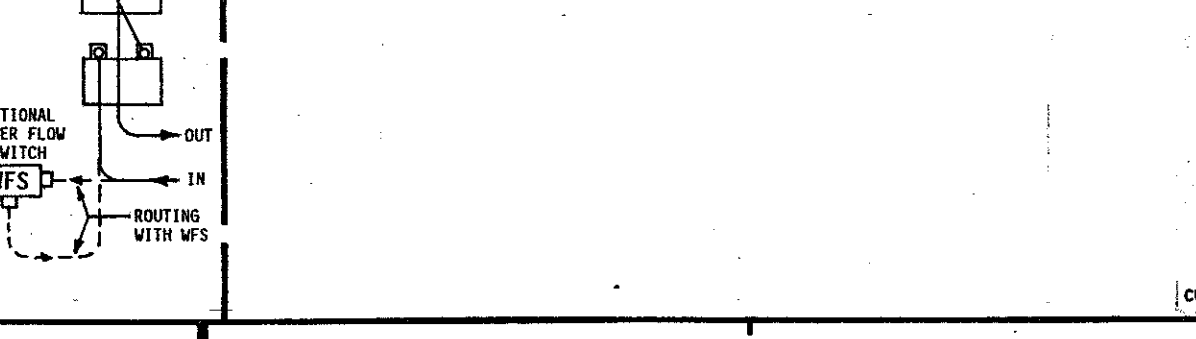
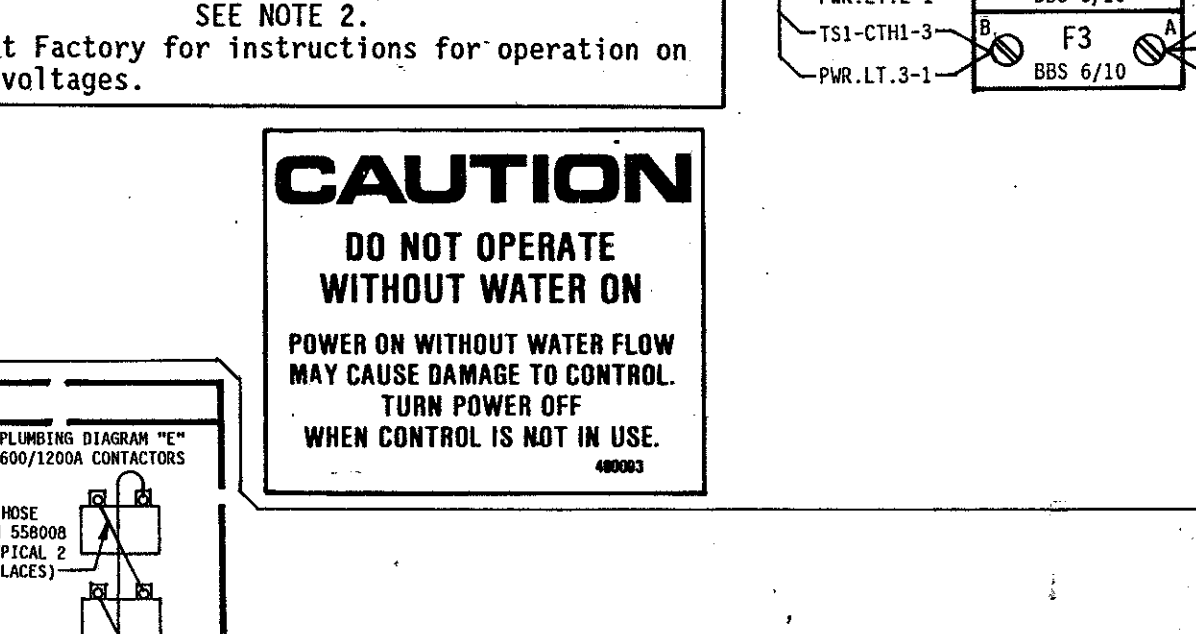
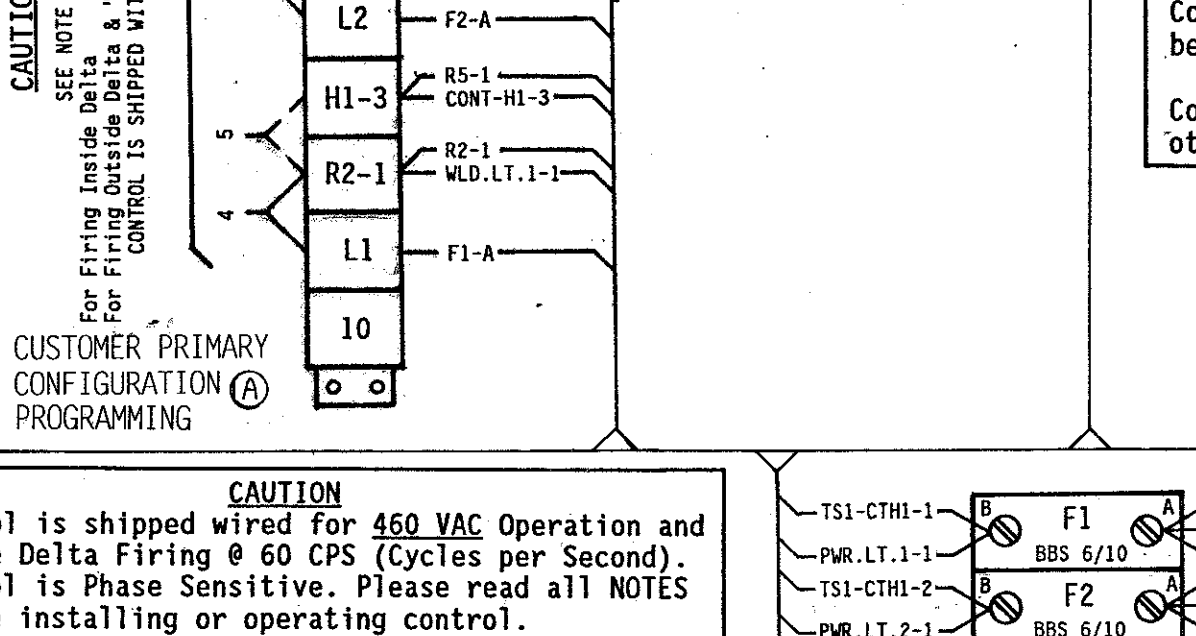
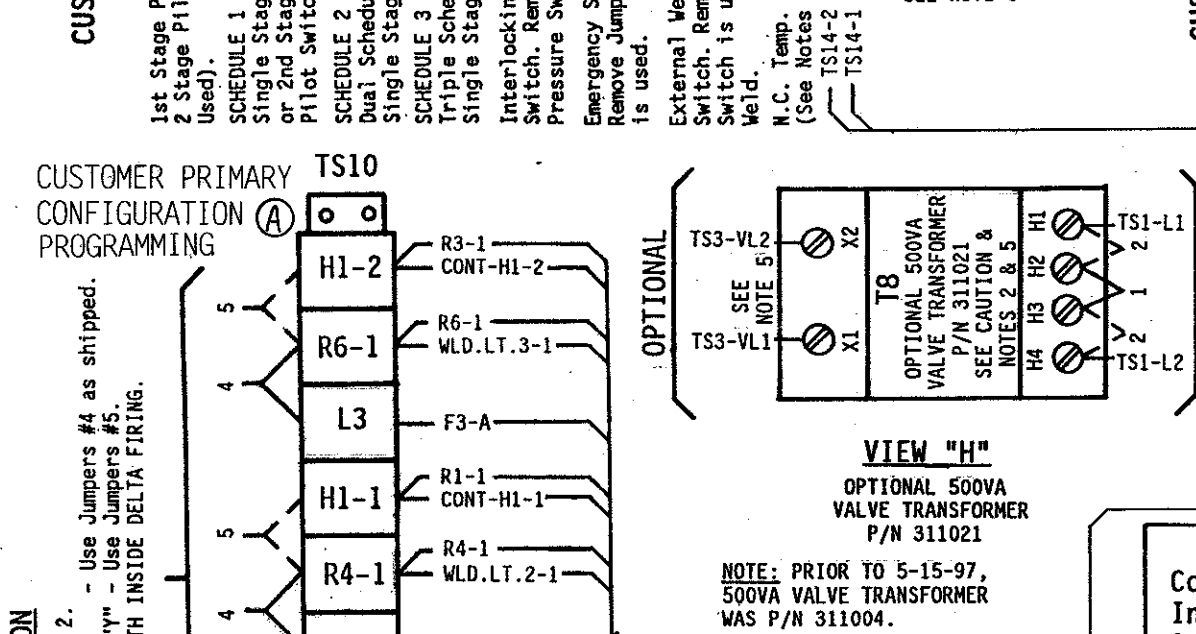
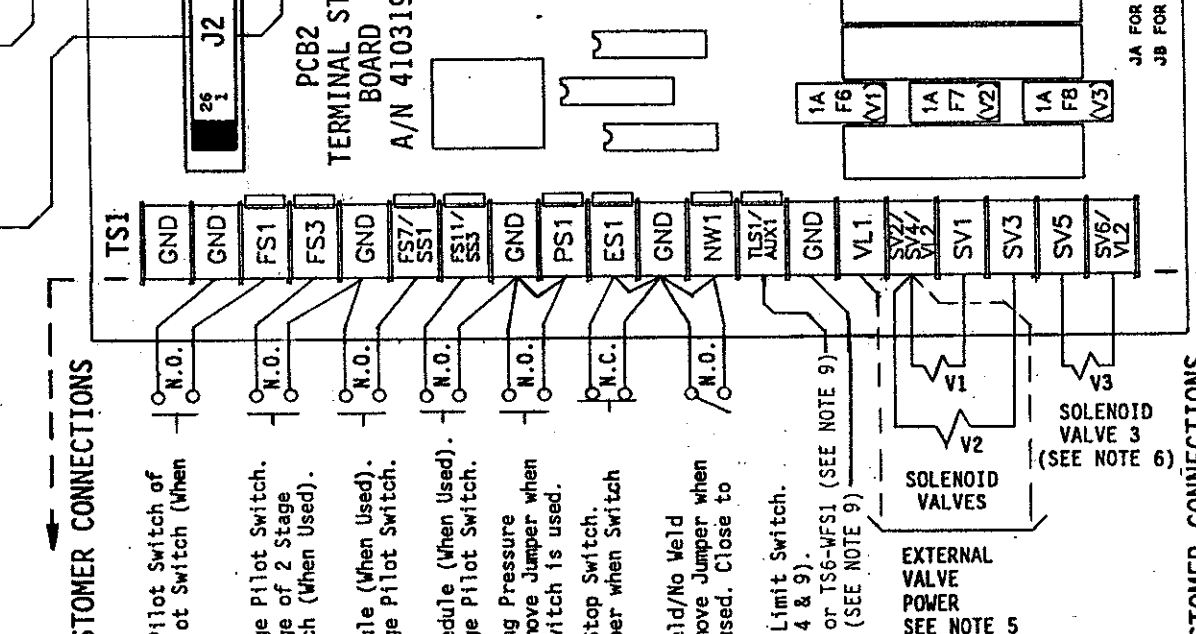
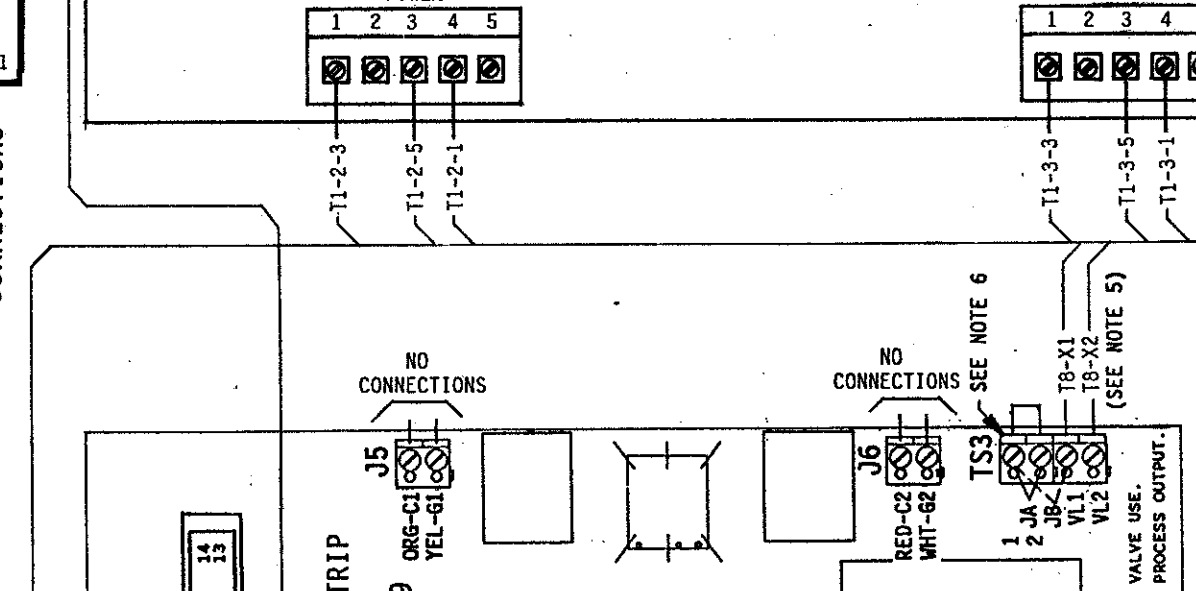
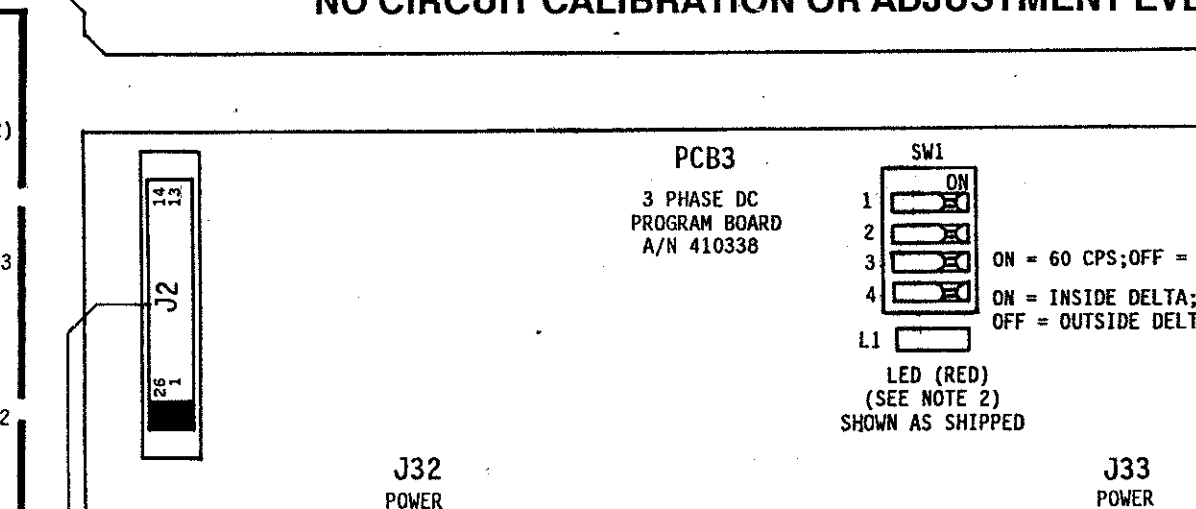
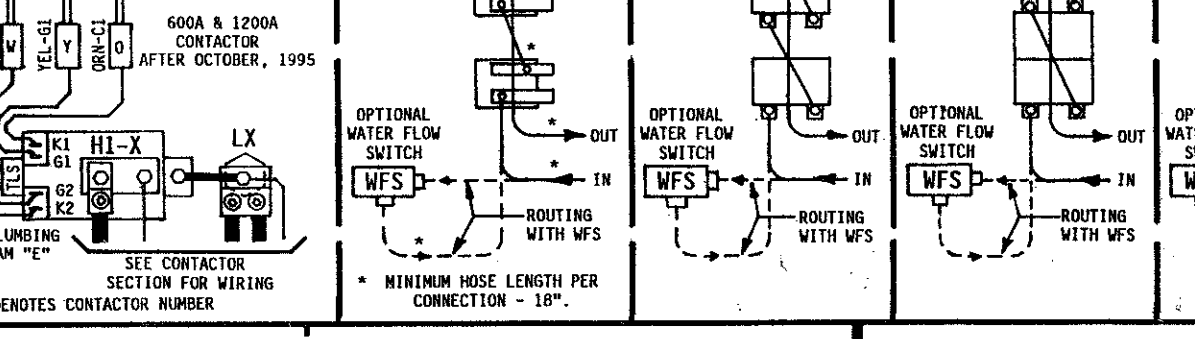
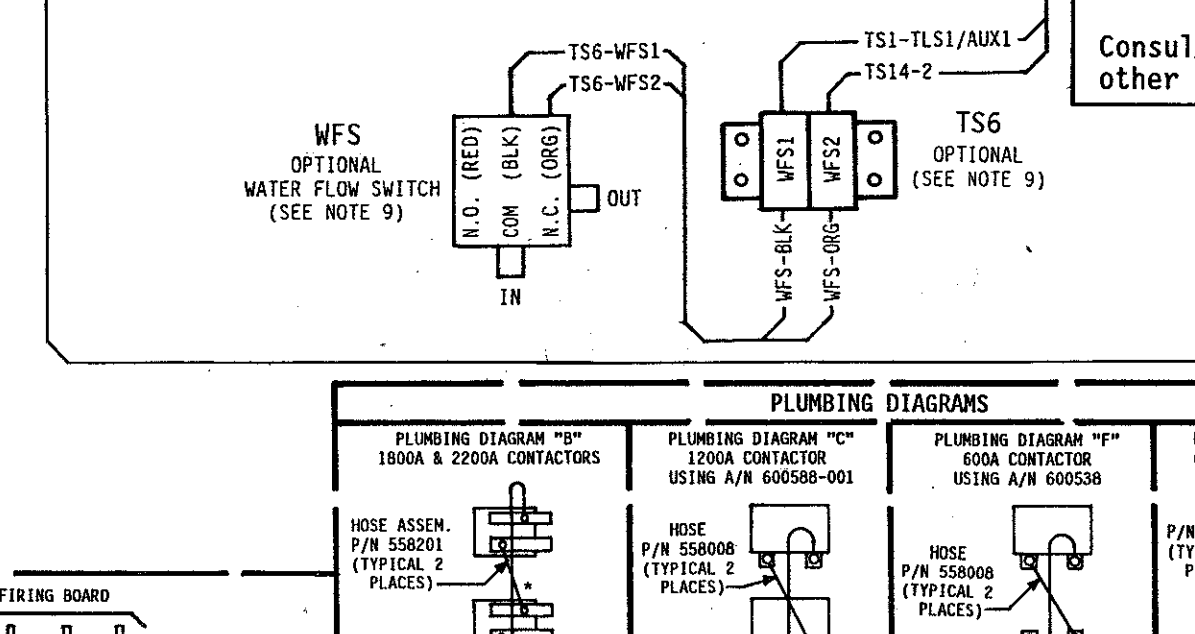
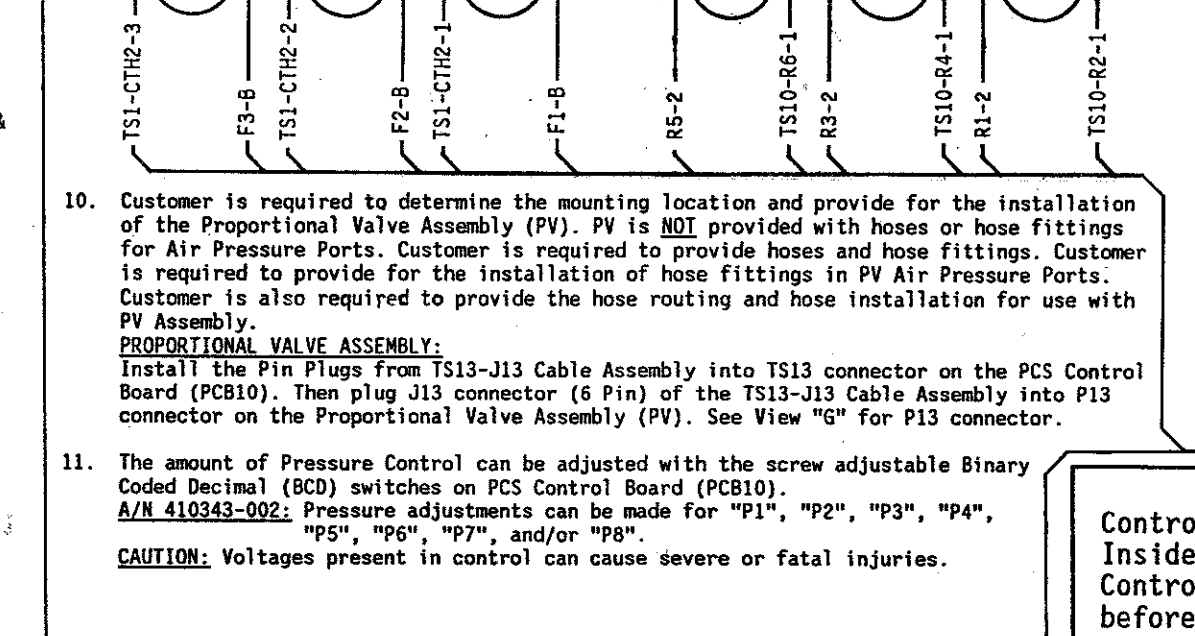
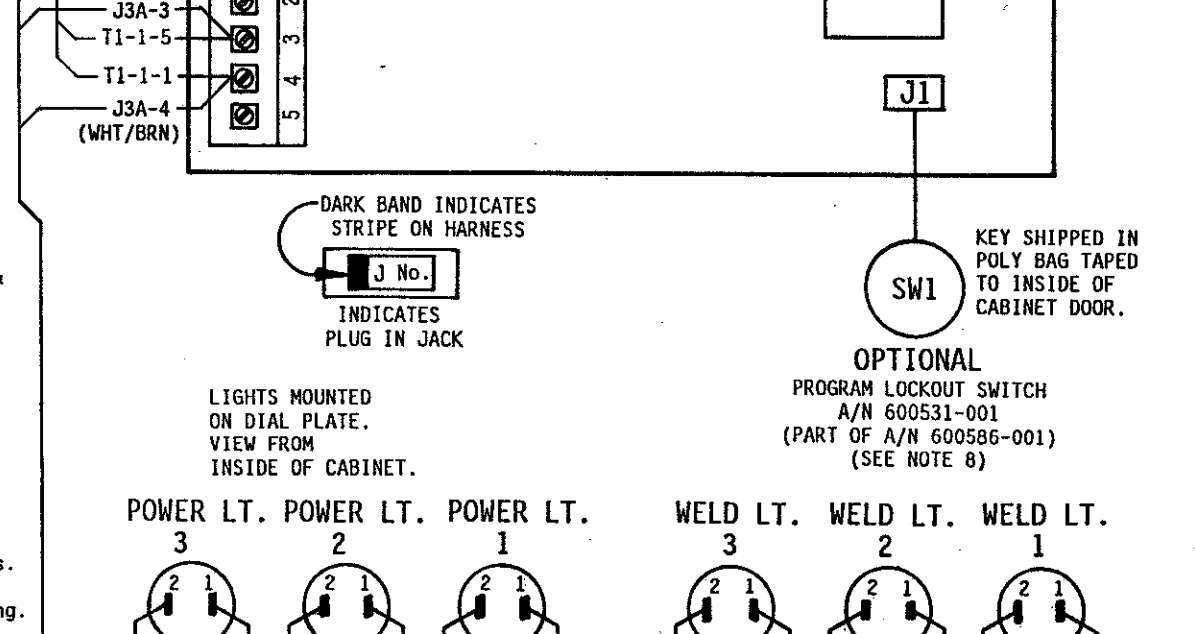
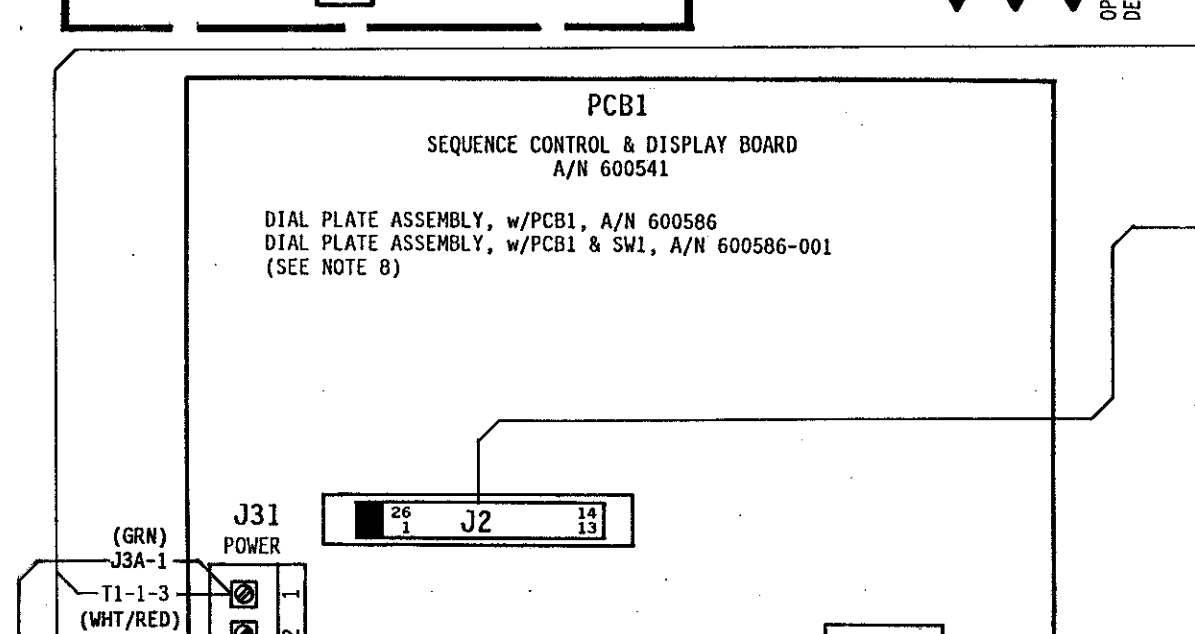
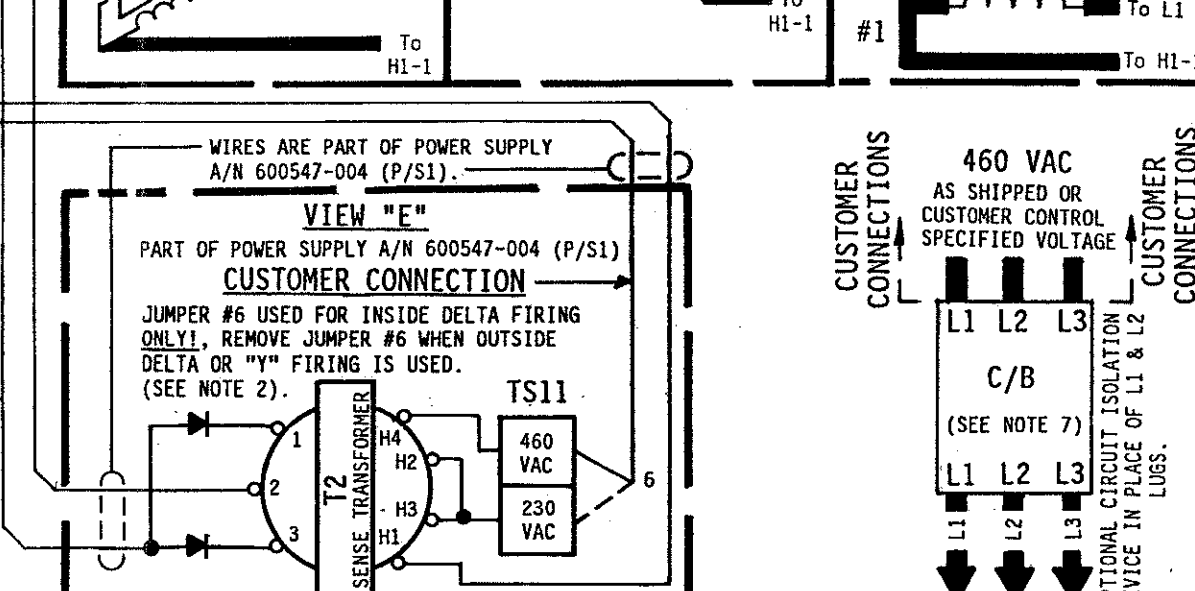
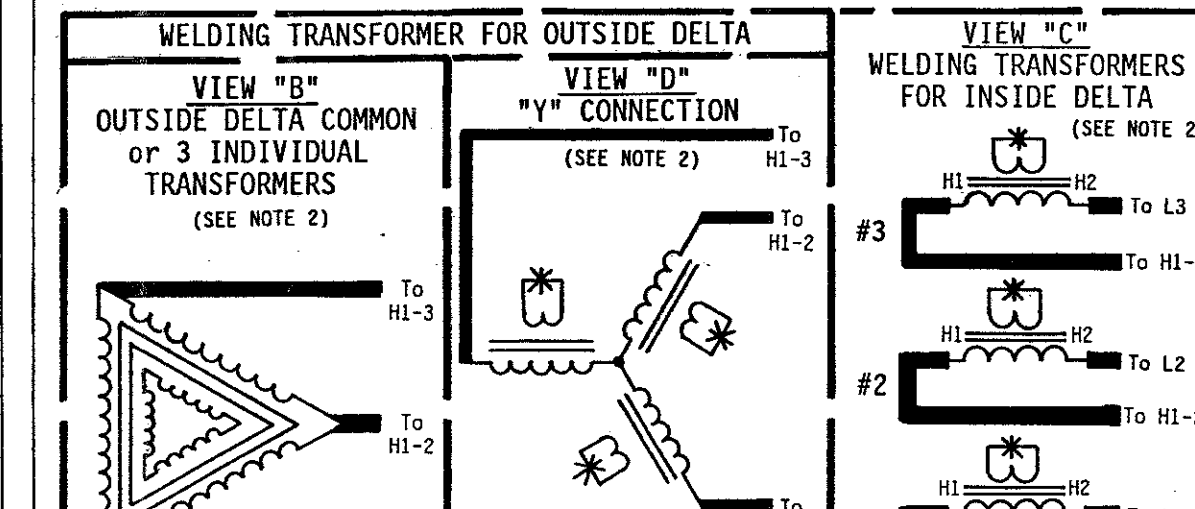
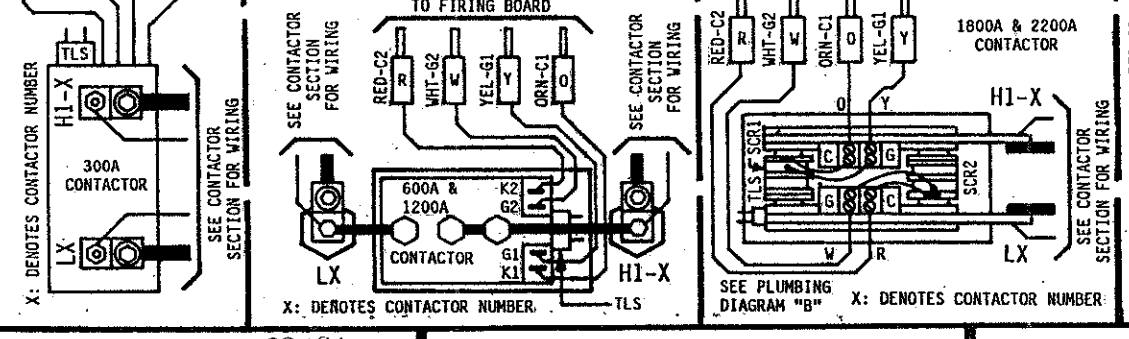
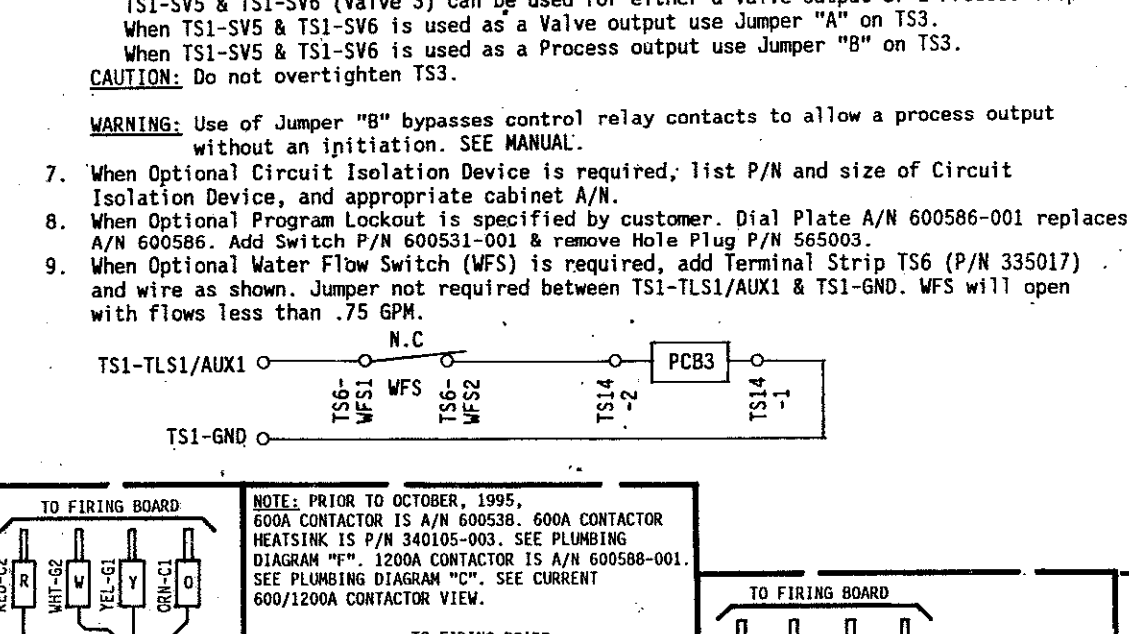
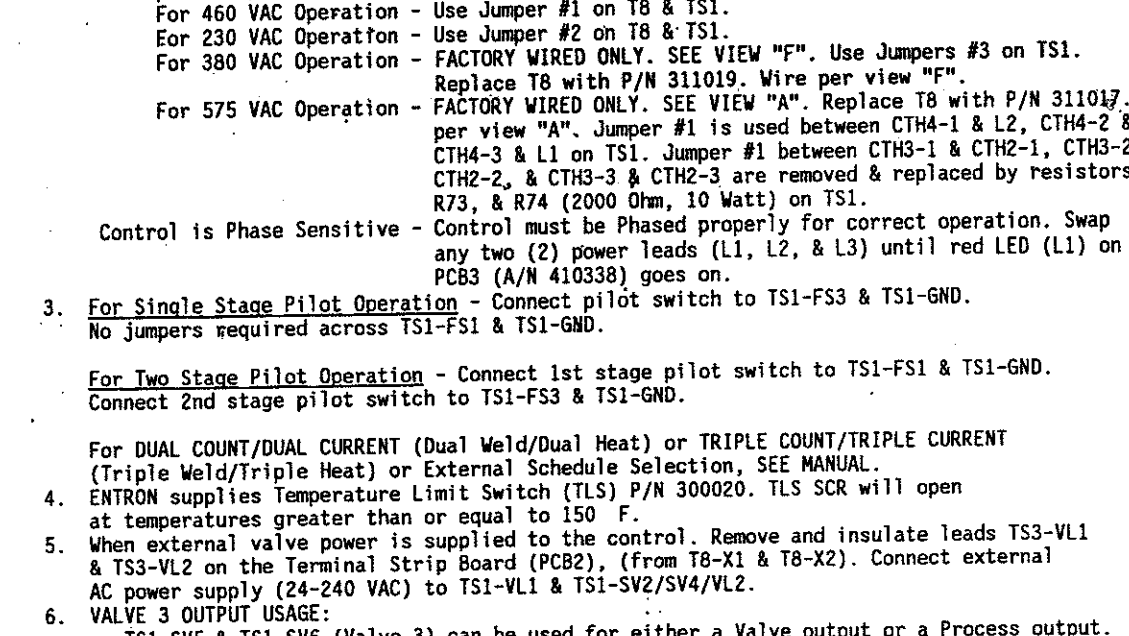
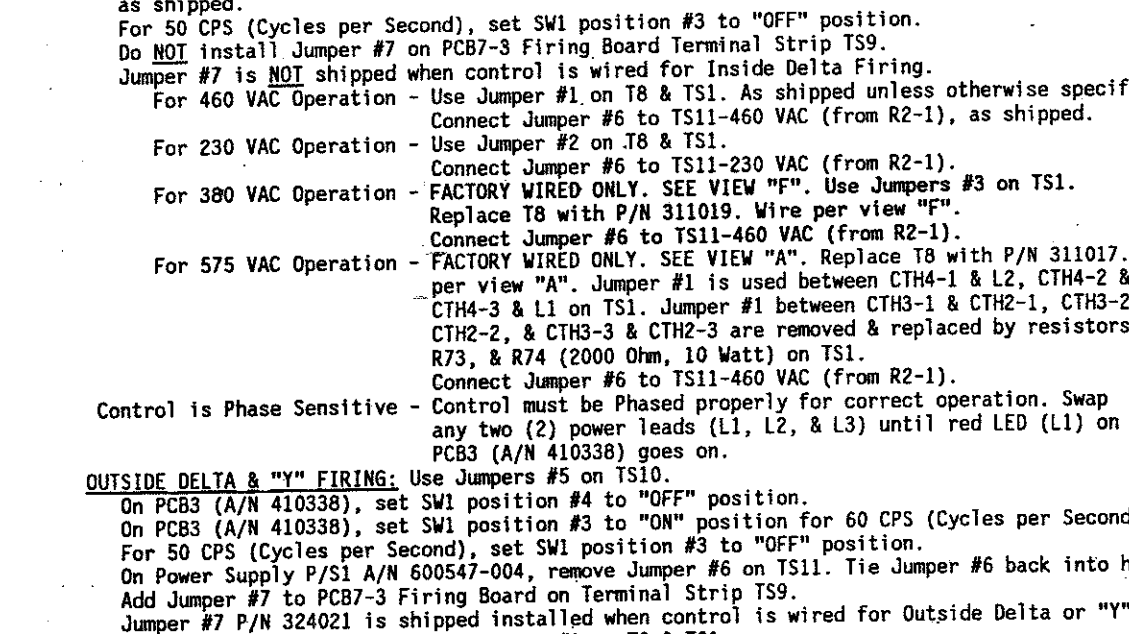
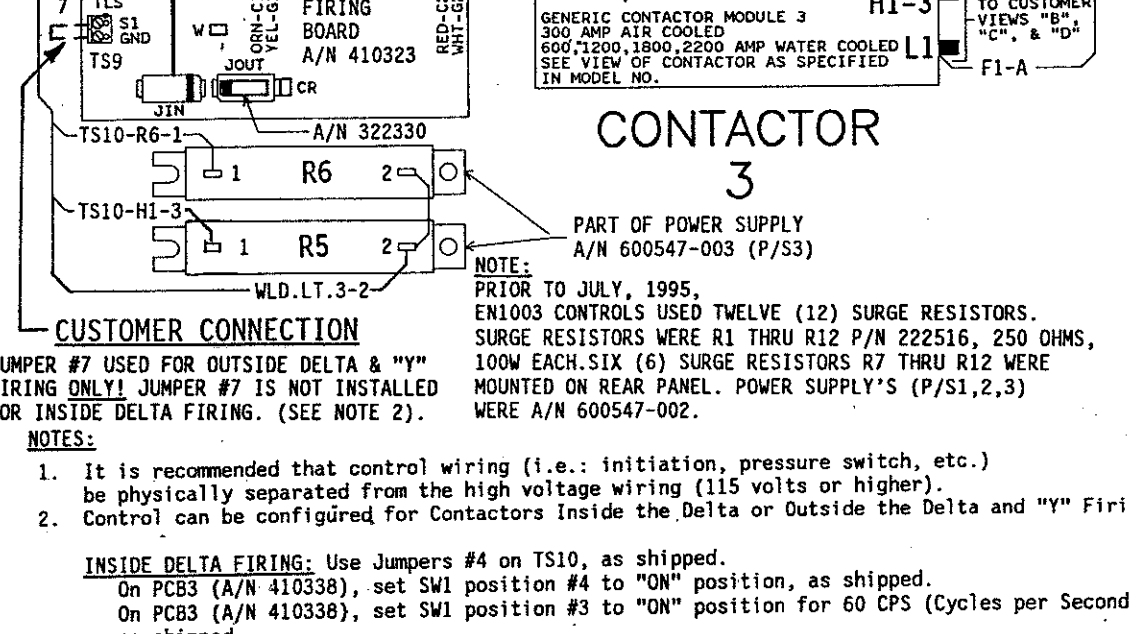
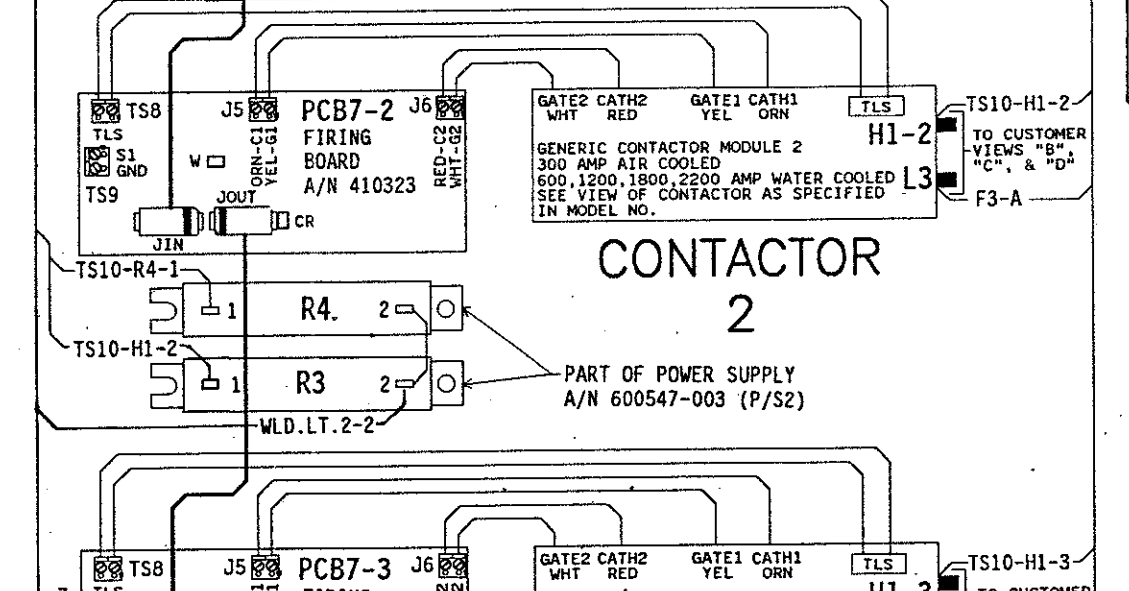
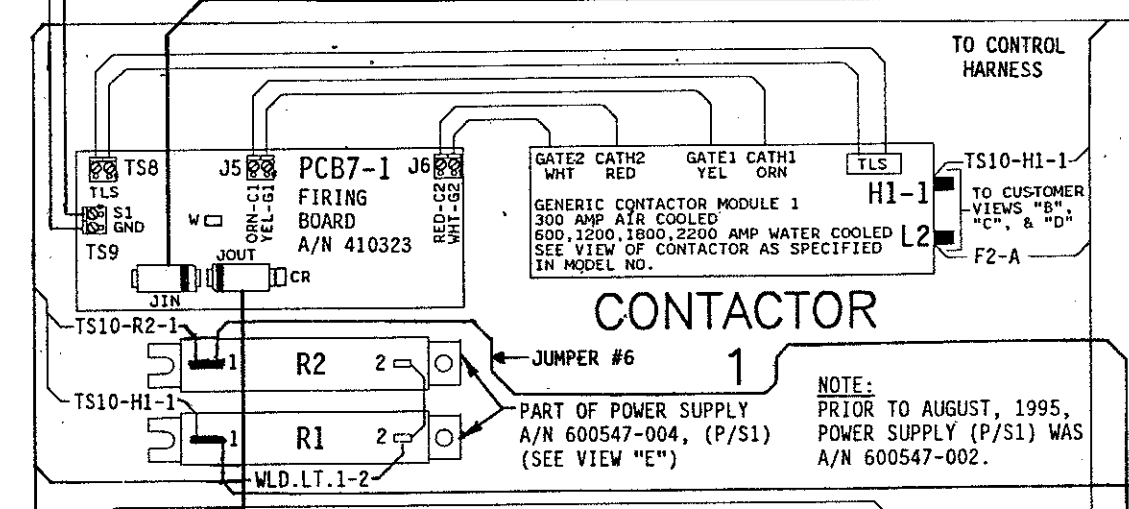

Table with 4 columns: QTY., DESIG., PART NO., DESCRIPTION. Lists various components like terminal strips, transformers, and control boards.

Table with 4 columns: QTY., DESIG., PART NO., DESCRIPTION. Lists various components like fuses, relays, and switches.

Table with 4 columns: QTY., DESIG., PART NO., DESCRIPTION. Lists various components like contactors, valves, and sensors.

Table with 4 columns: QTY., DESIG., PART NO., DESCRIPTION. Lists various components like cabinets, manuals, and wiring diagrams.

Table with 4 columns: QTY., DESIG., PART NO., DESCRIPTION. Lists various components like valves, sensors, and actuators.

FOR SERVICE ON THIS CONTROL CONTACT YOUR MACHINE DEALER OR ENTRON CONTROLS INC. DIRECTLY: (630) 682-9000

CAUTION Control is shipped wired for 460 VAC Operation and Inside Delta Firing @ 60 CPS (Cycles per Second). Control is Phase Sensitive. Please read all NOTES before installing or operating control.

CAUTION DO NOT OPERATE WITHOUT WATER ON POWER ON WITHOUT WATER FLOW MAY CAUSE DAMAGE TO CONTROL. TURN POWER OFF WHEN CONTROL IS NOT IN USE.

HAZARDOUS VOLTAGE FROM ONE OR MORE SOURCES. Turn Off All Voltage Sources Before Touching Any Components.

ENTRON CONTROLS INC.

SCALE DATE DRAWN BY CHK'D BY APPROVED BY. Includes drawing details and revision history.

WIRING DIAGRAM, EN1003-SERIES/PCS, "LS", "LF", "HS", or "HF" CABINET. Includes part numbers and descriptions.