

CAUTION - READ MANUAL & ALL NOTES BEFORE INSTALLING OR OPERATING CONTROL. SEE NOTE 1. NO CIRCUIT CALIBRATION OR ADJUSTMENT EVER REQUIRED.

4 DANGER HAZARDOUS VOLTAGE FROM ONE OR MORE SOURCES Turn off all voltage sources before touching any components. Electrical shock or flash will cause severe injury or death.

NOTICE FOR SERVICE ON THIS CONTROL Contact Your Machine Dealer Or ENTRON CONTROLS INC. DIRECTLY (630) 682-9888 485 EAST RANDY ROAD CAROL STREAM, IL 60188 FAX # (630) 682-3374

421418 PARTS LIST - CONTROL SECTION

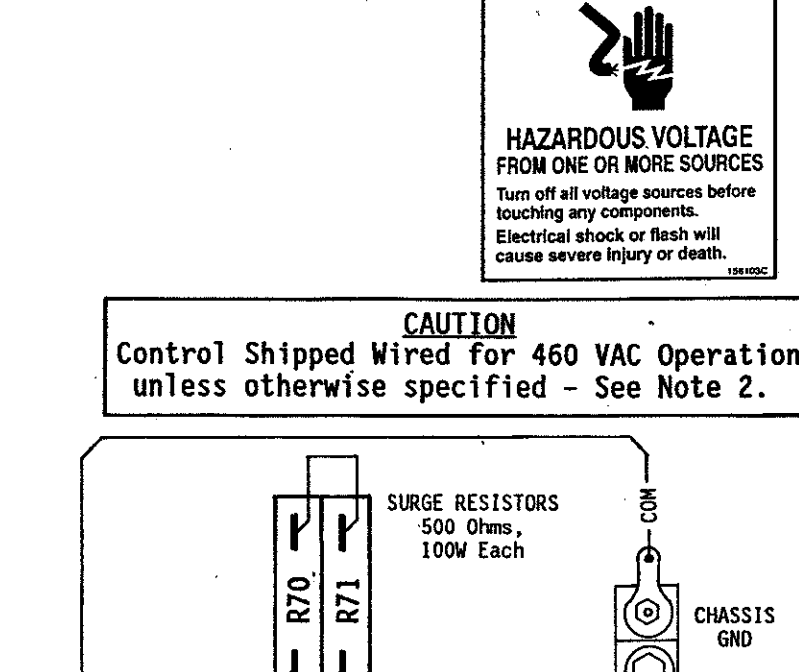
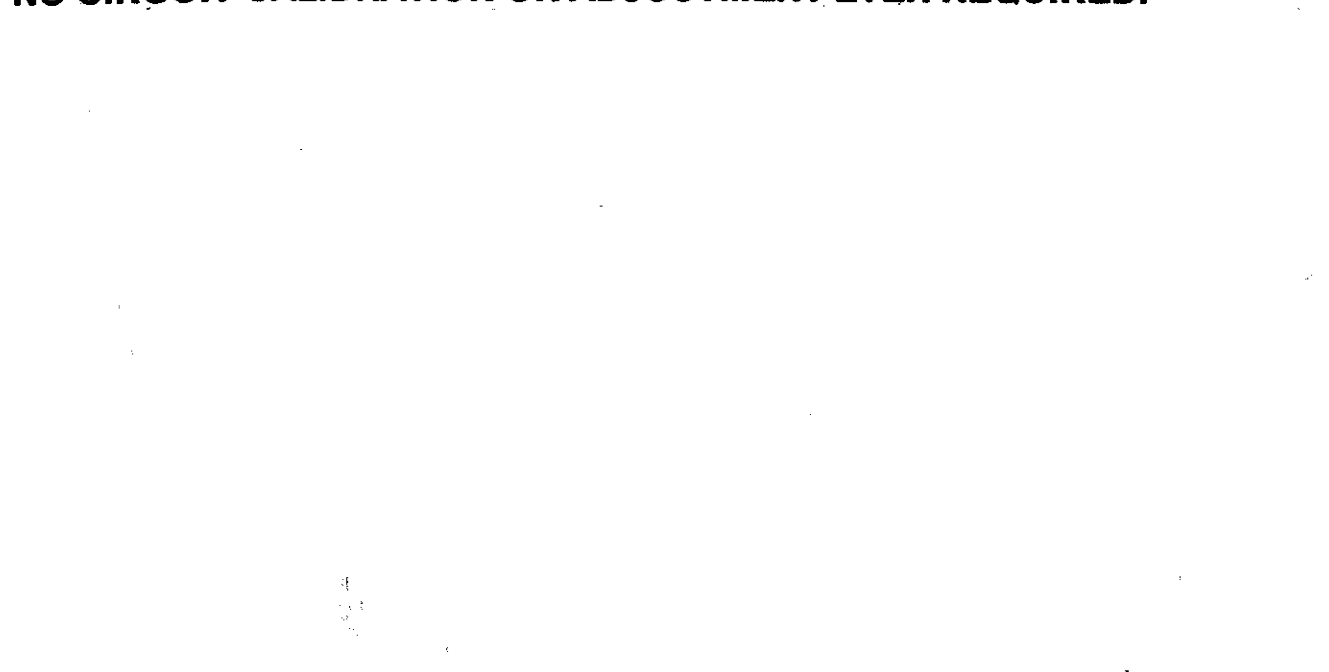
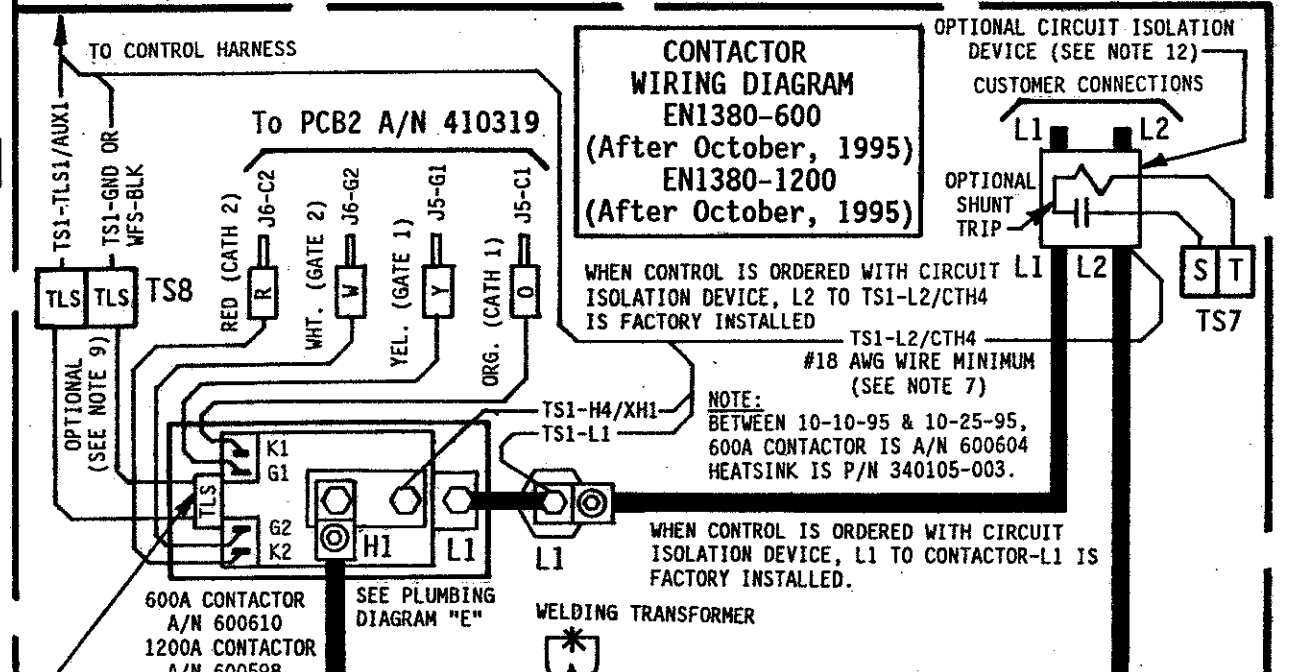
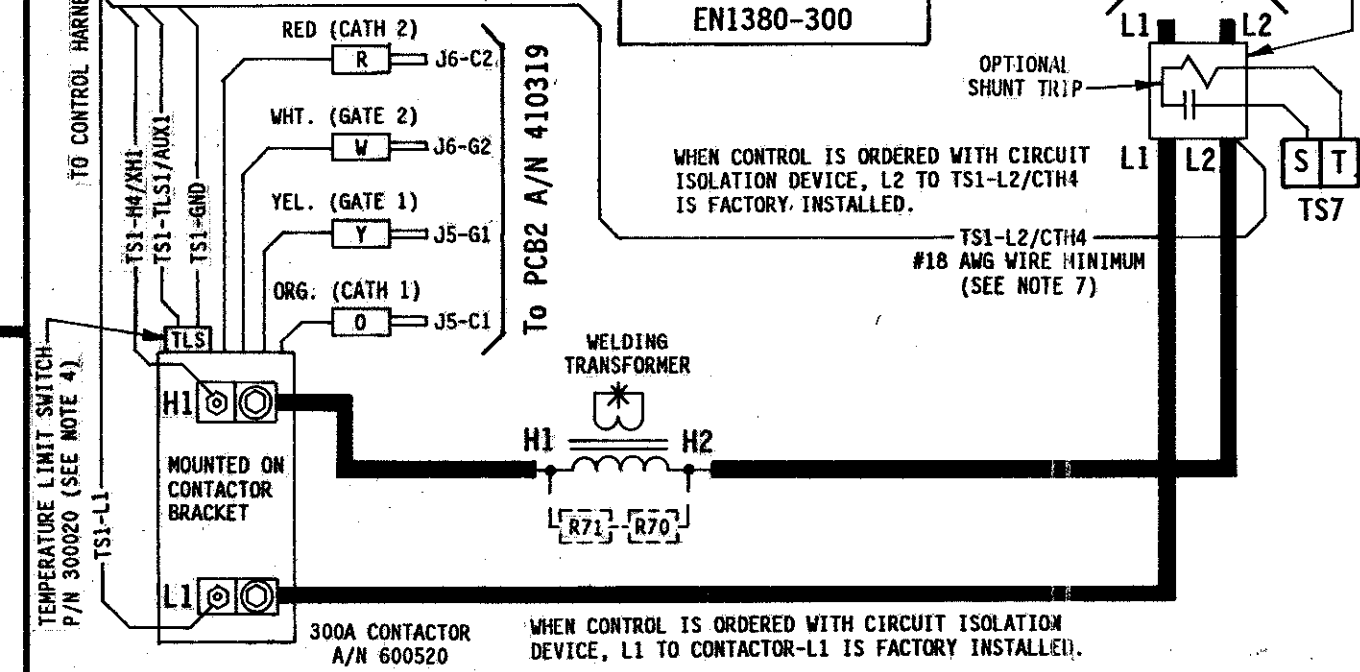

Table with 4 columns: QTY, DESIG., PART NO., DESCRIPTION. Lists parts for control section including dial plate, switch, sequence control, and various transformers.

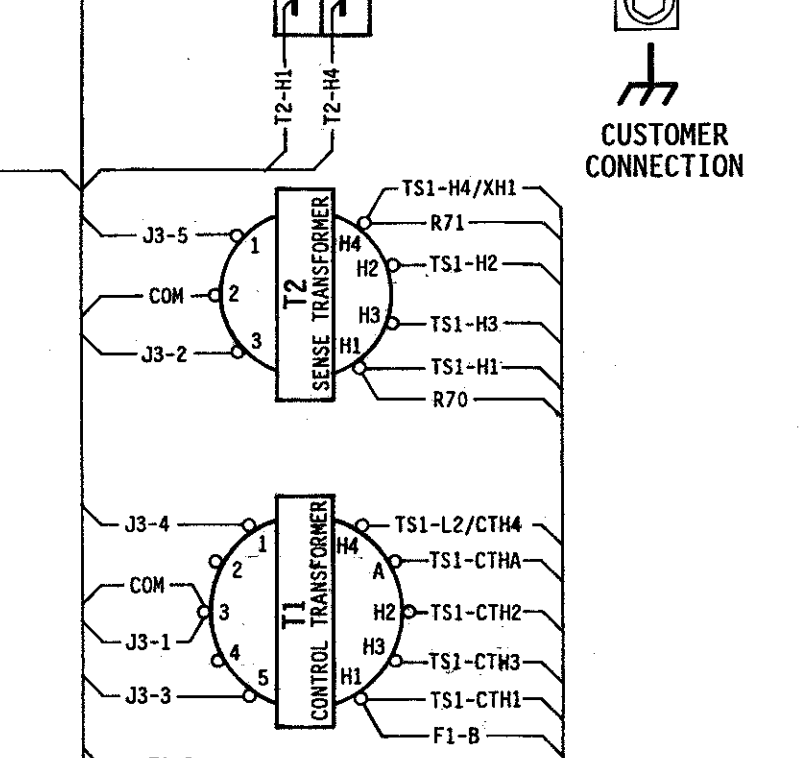
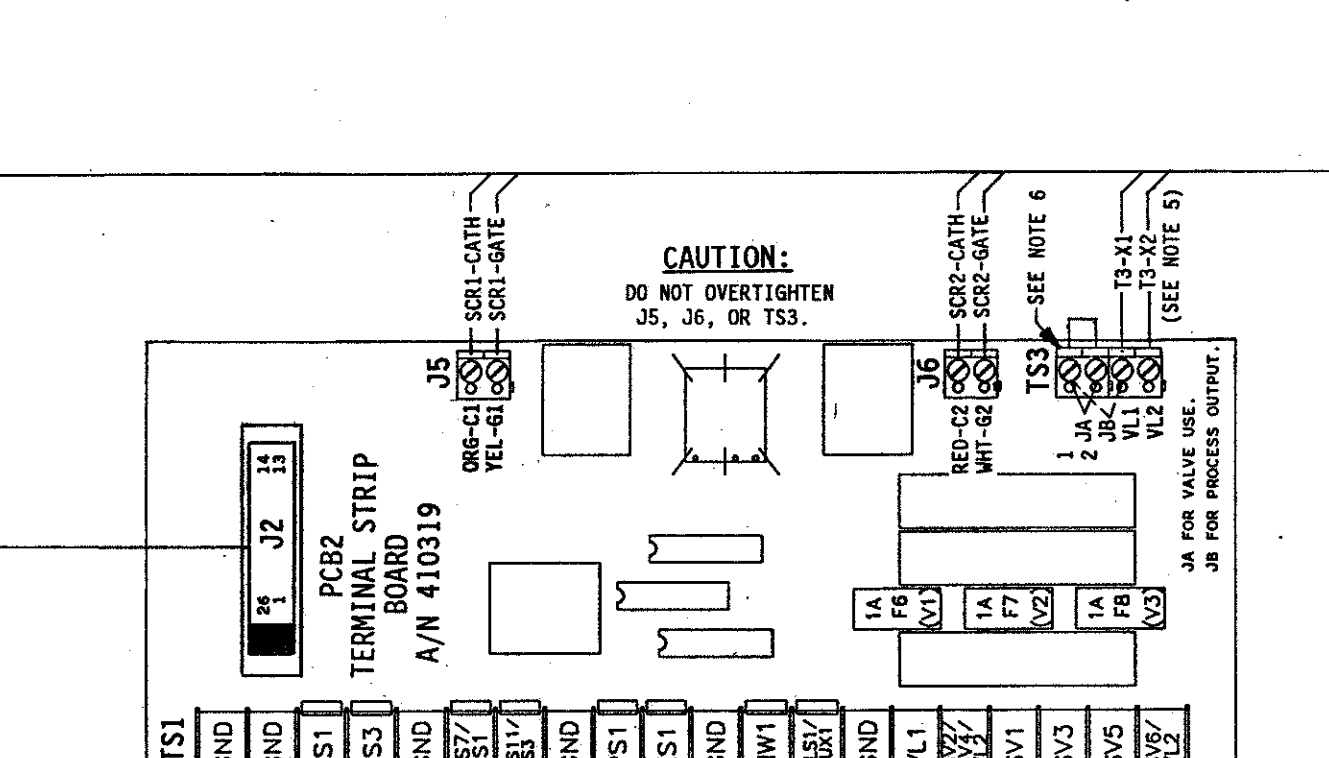
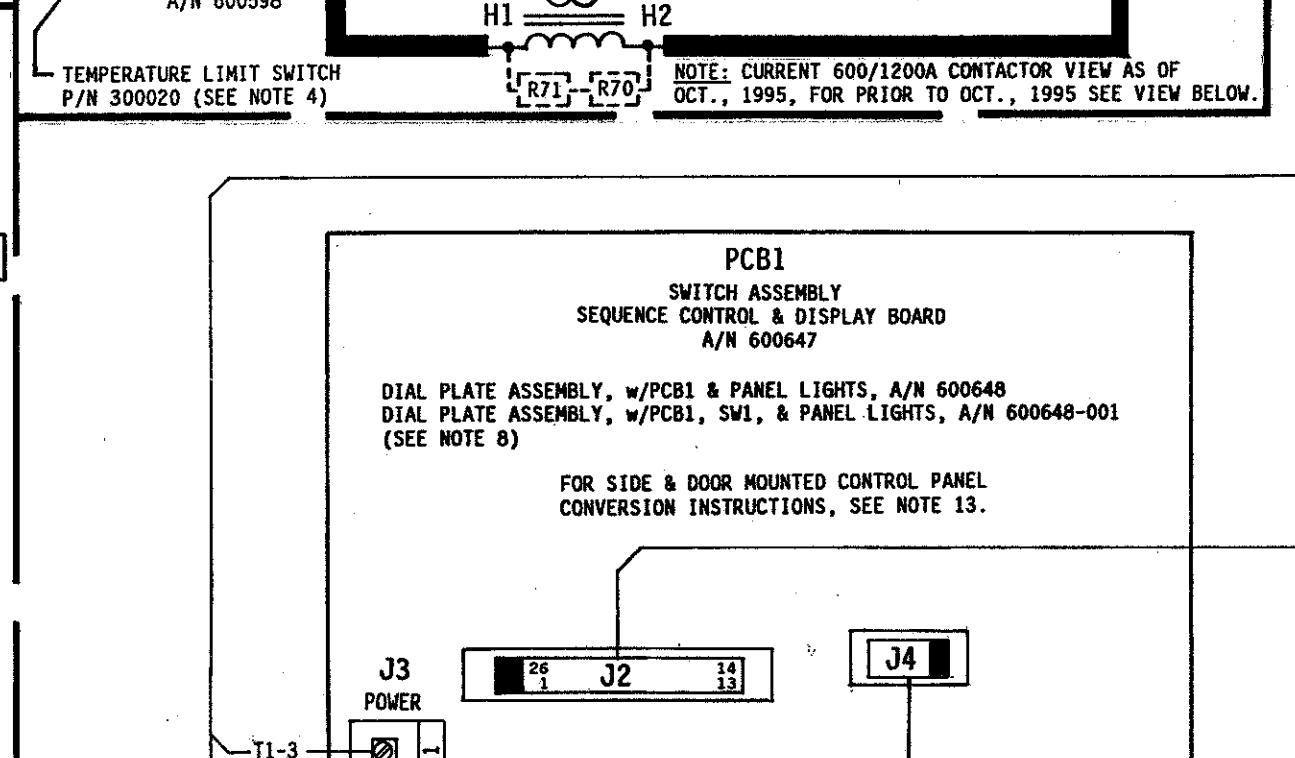
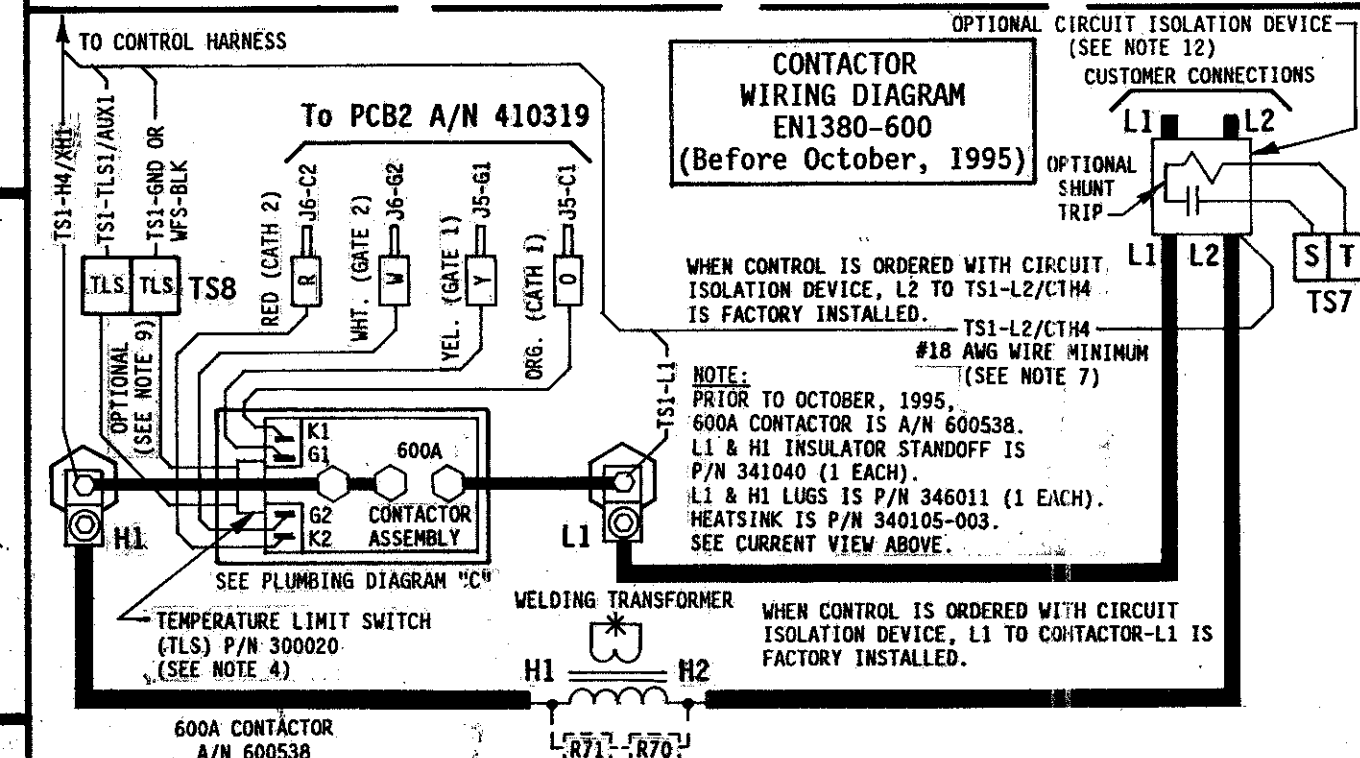

Table with 4 columns: QTY, DESIG., PART NO., DESCRIPTION. Lists parts for contactor section including terminal strips, transformers, and resistors.

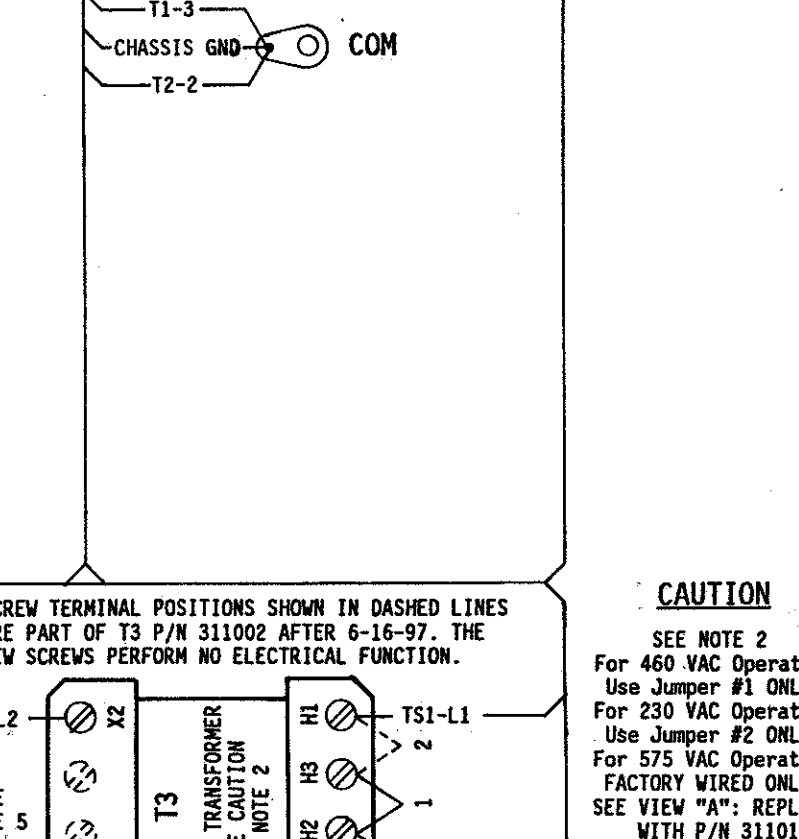
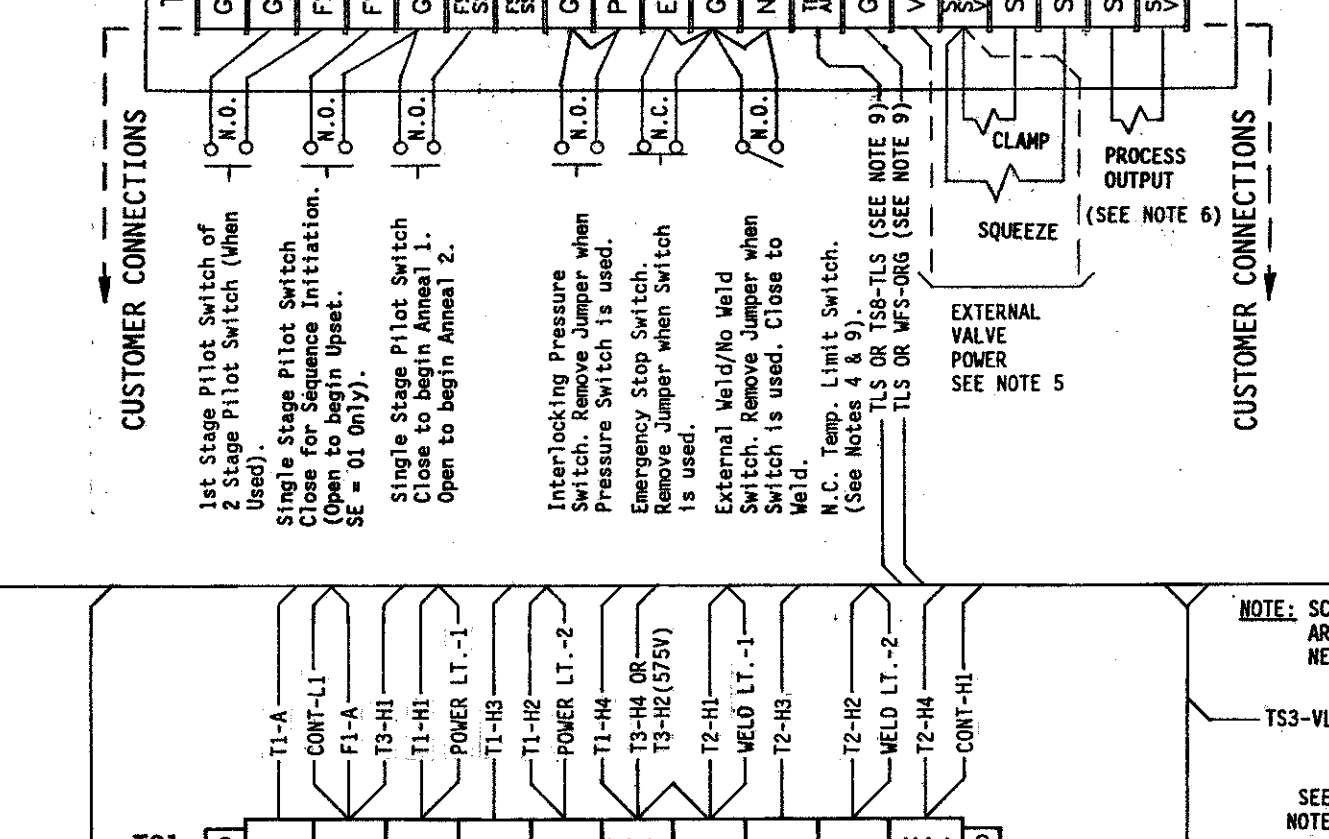
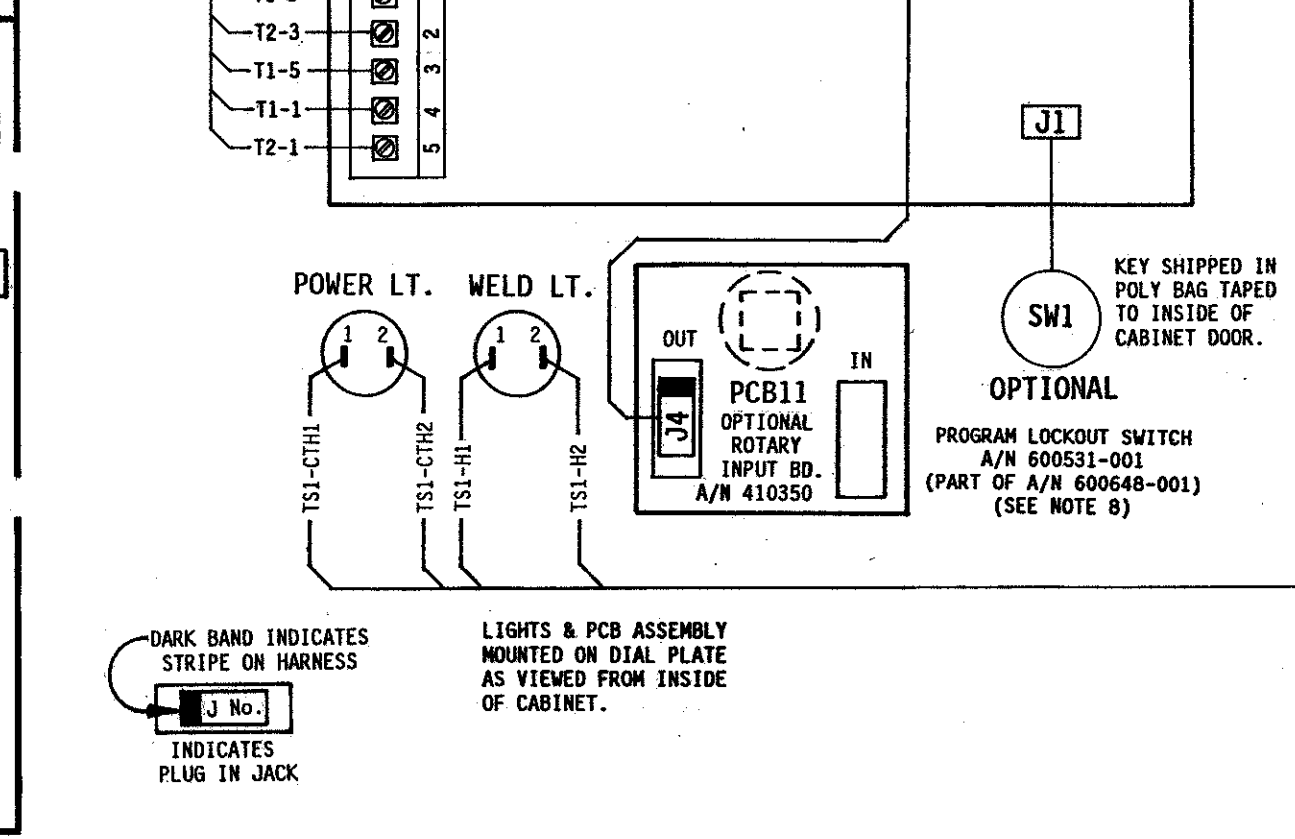
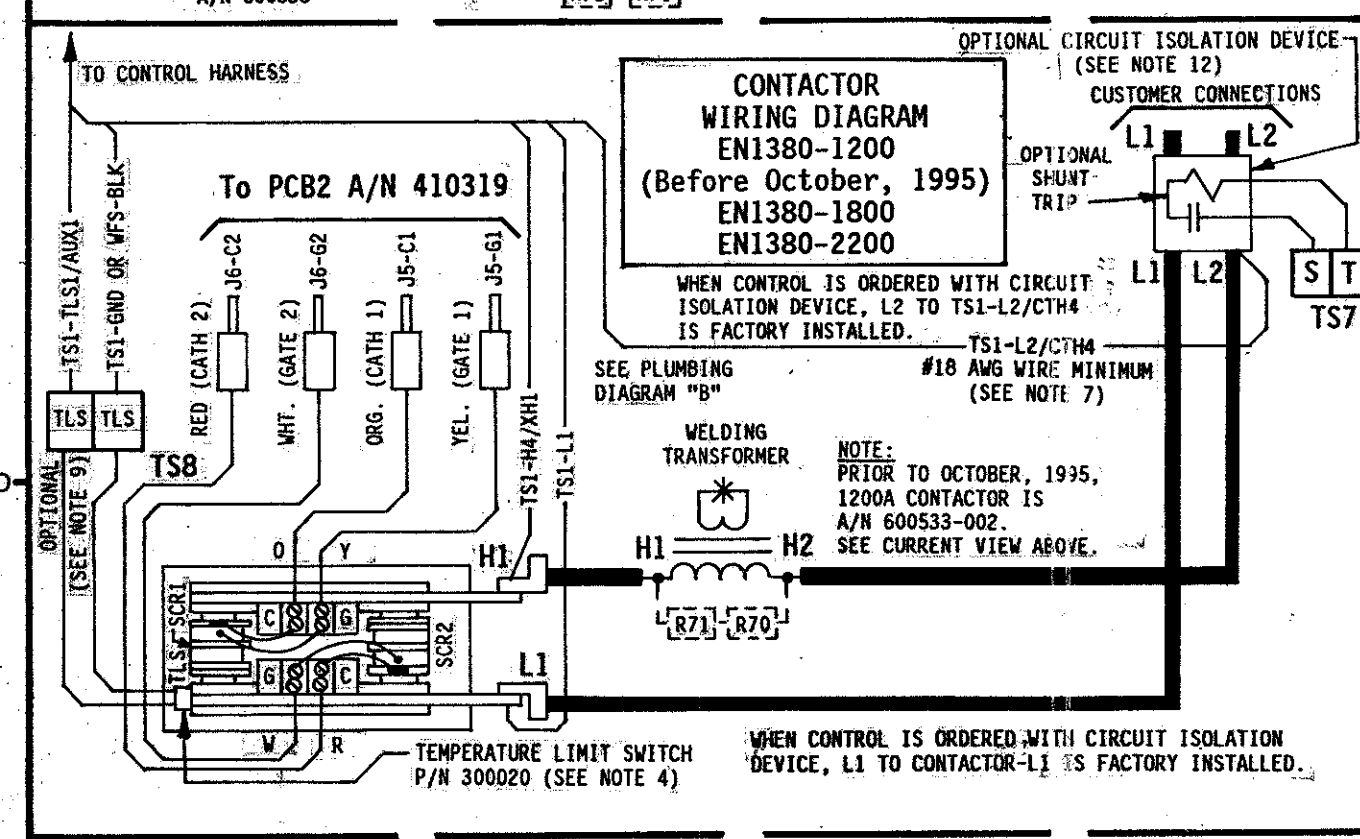

Table with 4 columns: QTY, DESIG., PART NO., DESCRIPTION. Lists parts for contactor section including terminal strips, transformers, and resistors.

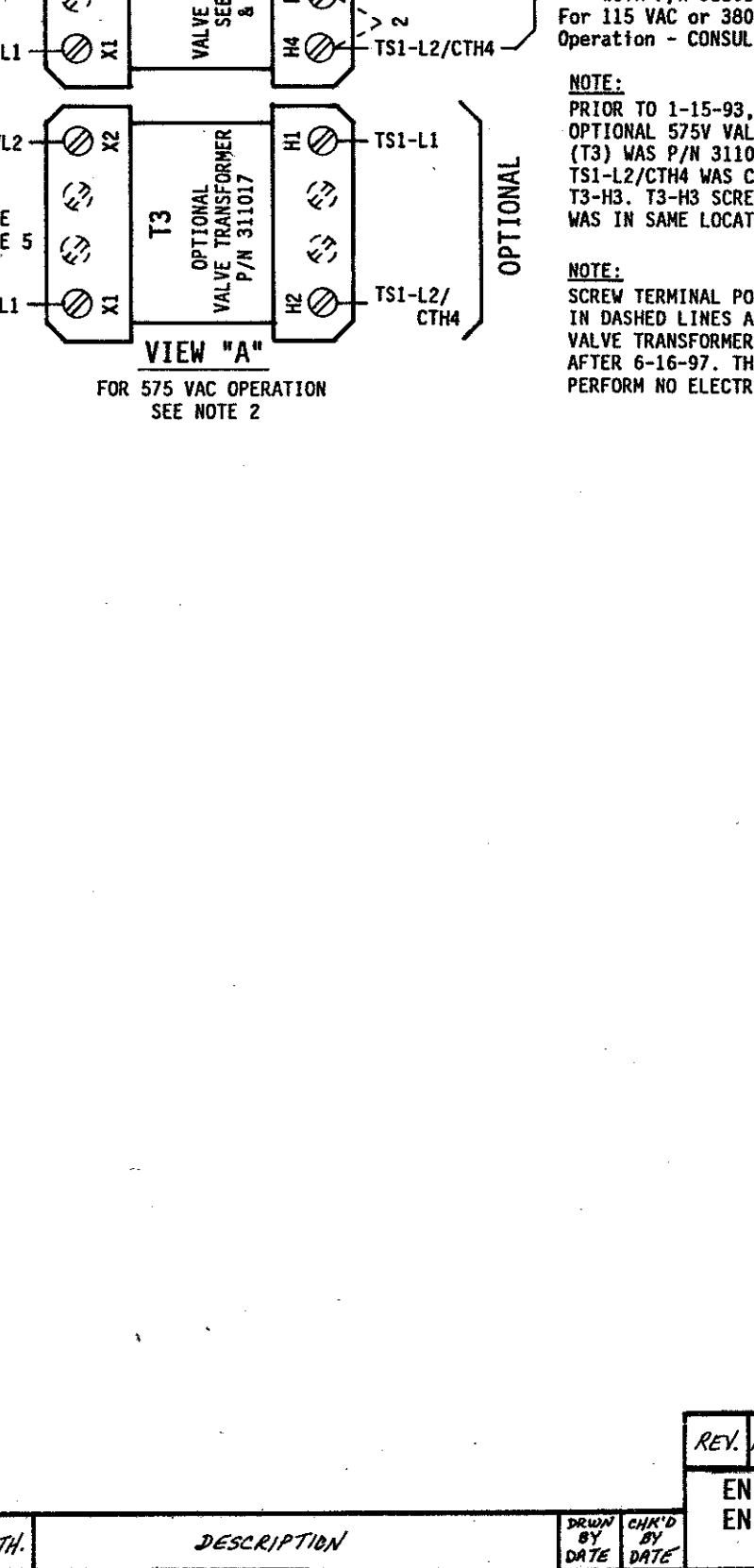
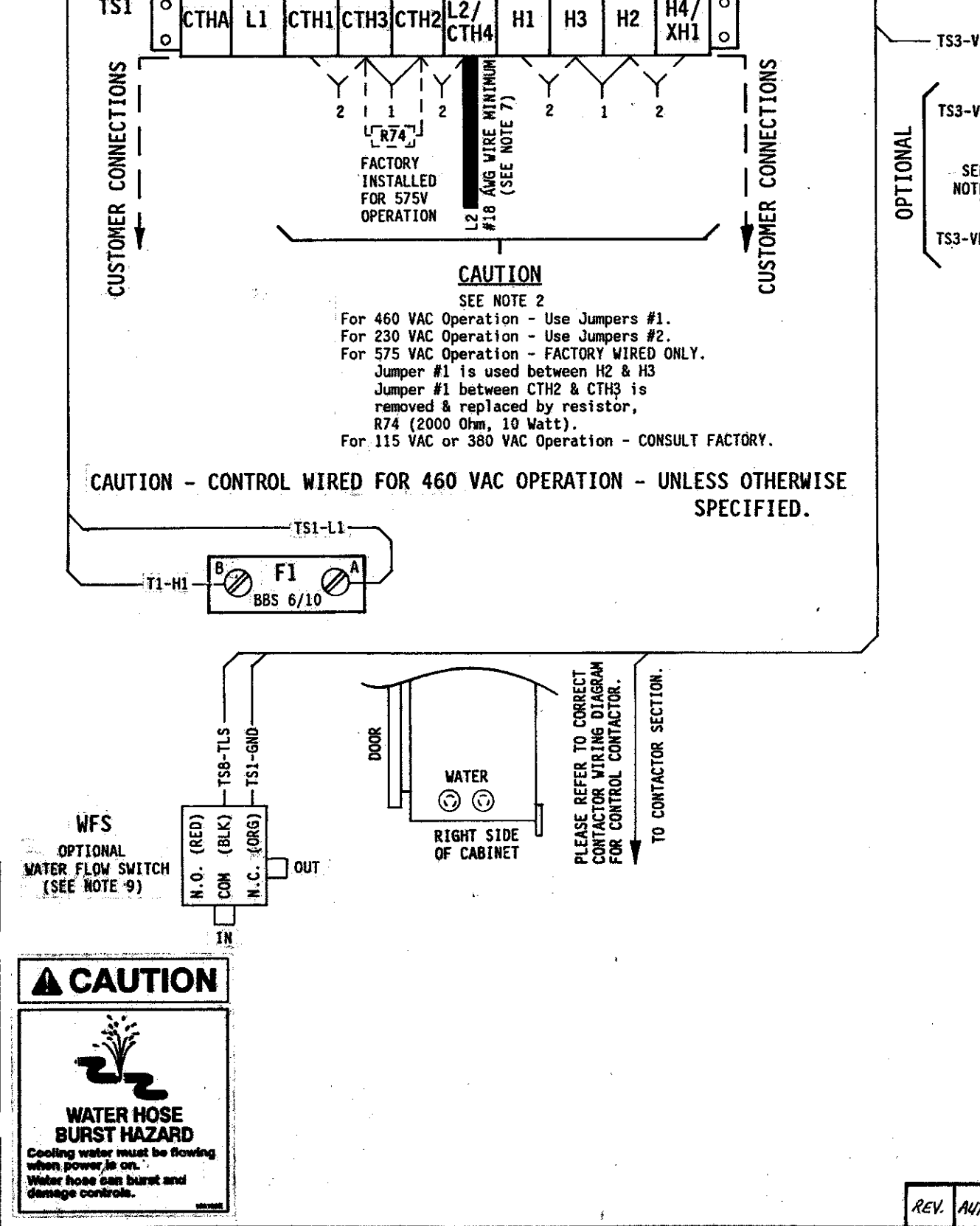
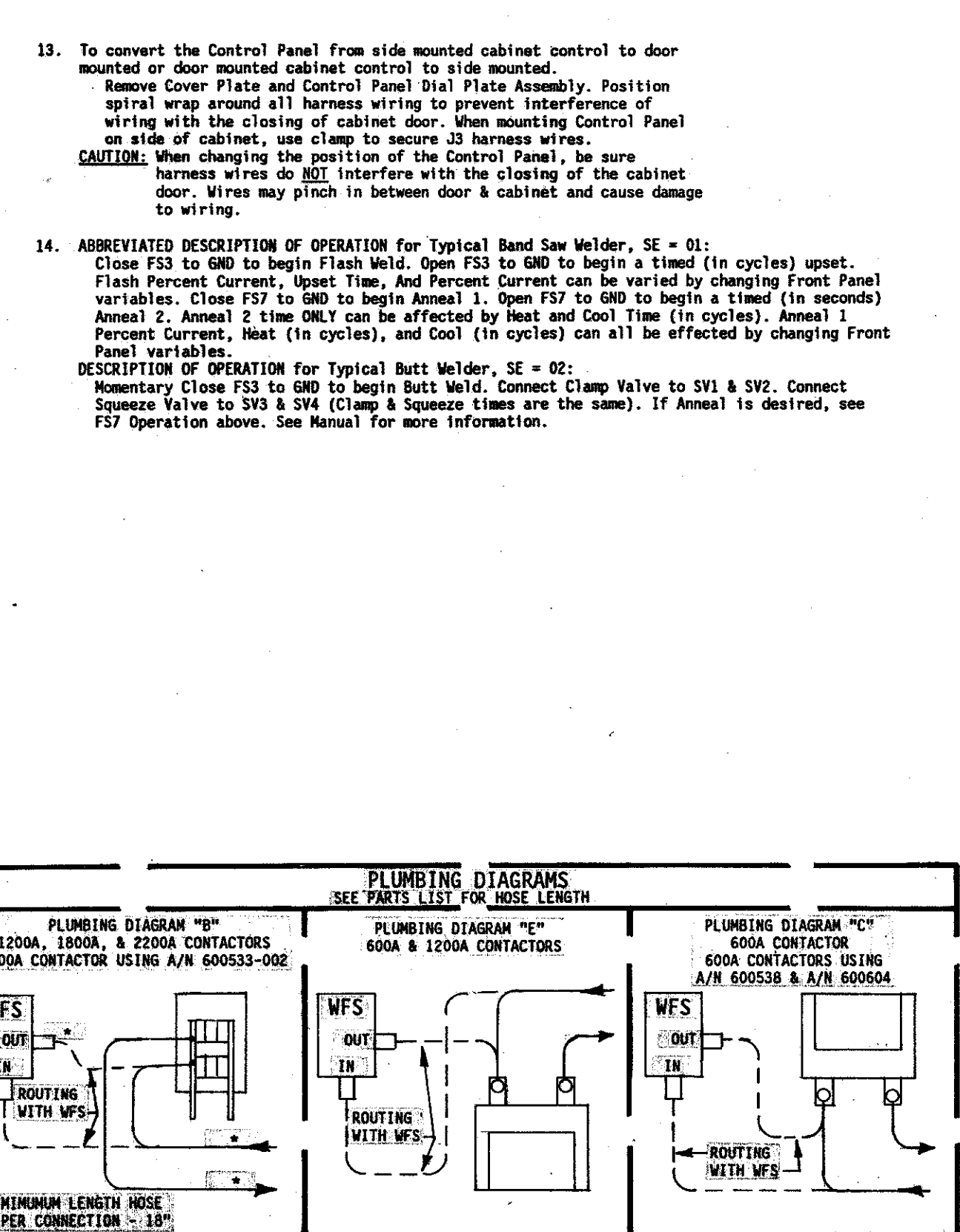
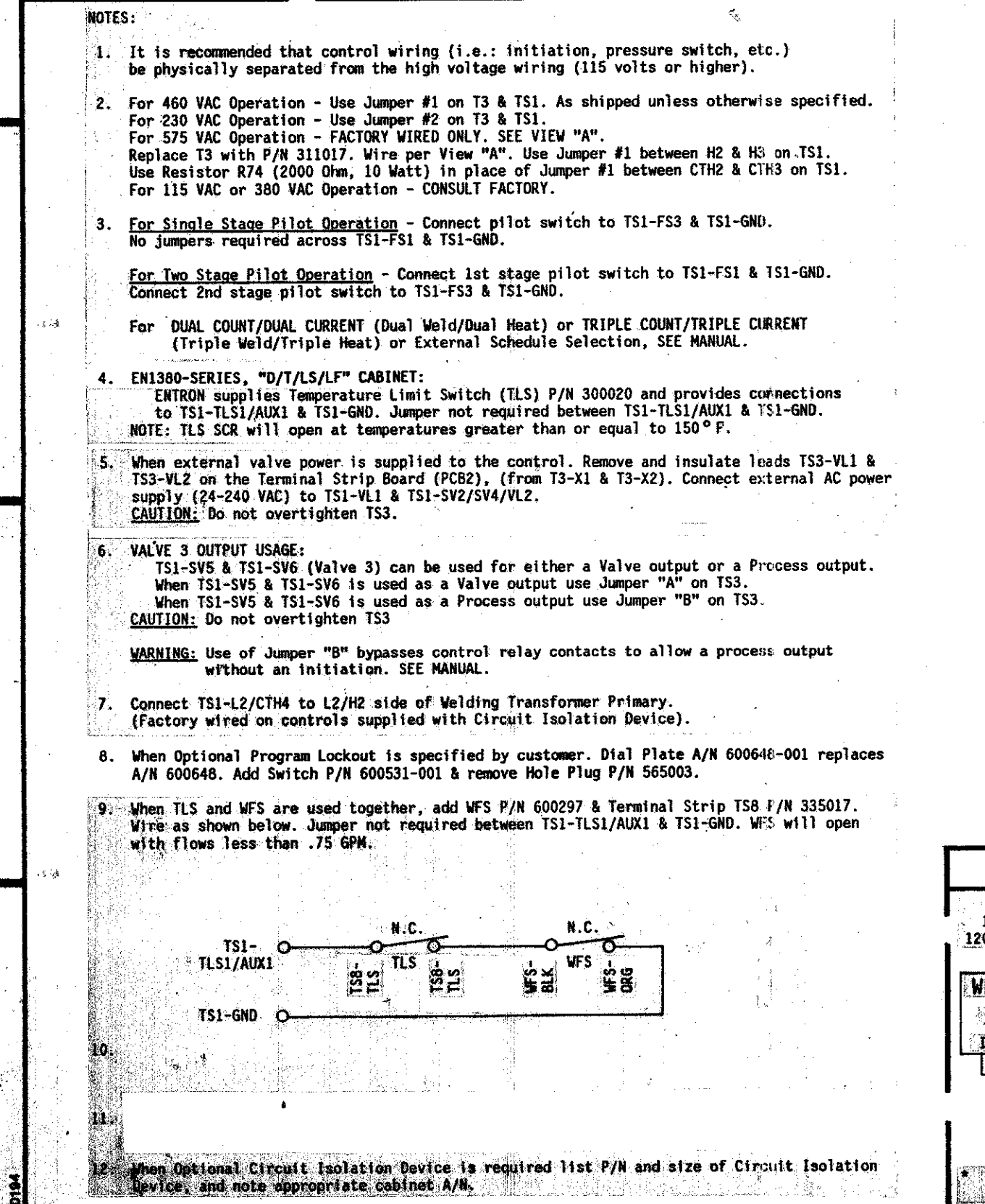

Table with 4 columns: QTY, DESIG., PART NO., DESCRIPTION. Lists parts for contactor section including terminal strips, transformers, and resistors.



Table with 4 columns: QTY, DESIG., PART NO., DESCRIPTION. Lists parts for contactor section including terminal strips, transformers, and resistors.

- 1. It is recommended that control wiring (i.e.: initiation, pressure switch, etc.) be physically separated from the high voltage wiring (115 volts or higher).
- 2. For 460 VAC Operation - Use Jumper #1 on T3 & T51. As shipped unless otherwise specified.
- 3. For Single Stage Pilot Operation - Connect pilot switch to T51-F53 & T51-GND.
- 4. EN1380-SERIES, "D/T/LS/LF" CABINET: ENTRON supplies Temperature Limit Switch (T51) P/N 300020 and provides connections to T51-TLS1/AUX1 & T51-GND.
- 5. When external valve power is supplied to the control, remove and insulate leads T53-VL1 & T53-VL2 on the Terminal Strip Board (TSB).
- 6. VALVE 3 OUTPUT USAGE: T51-SV5 & T51-SV6 (Valve 3) can be used for either a Valve output or a Process output.
- 7. Connect T51-L2/CTH4 to L2/H2 side of Welding Transformer Primary.
- 8. When Optional Program Lockout is specified by customer, Dial Plate A/N 600648-001 replaces A/N 600648.
- 9. When TLS and MFS are used together, add MFS P/N 600297 & Terminal Strip T58 P/N 335017.

- 13. To convert the Control Panel from side mounted cabinet control to door mounted or door mounted cabinet control to side mounted.
- 14. ABBREVIATED DESCRIPTION OF OPERATION FOR Typical Band Saw Welder, SE = 01: Close FS3 to GND to begin Flash Weld. Open FS3 to GND to begin a time (in cycles) upset.

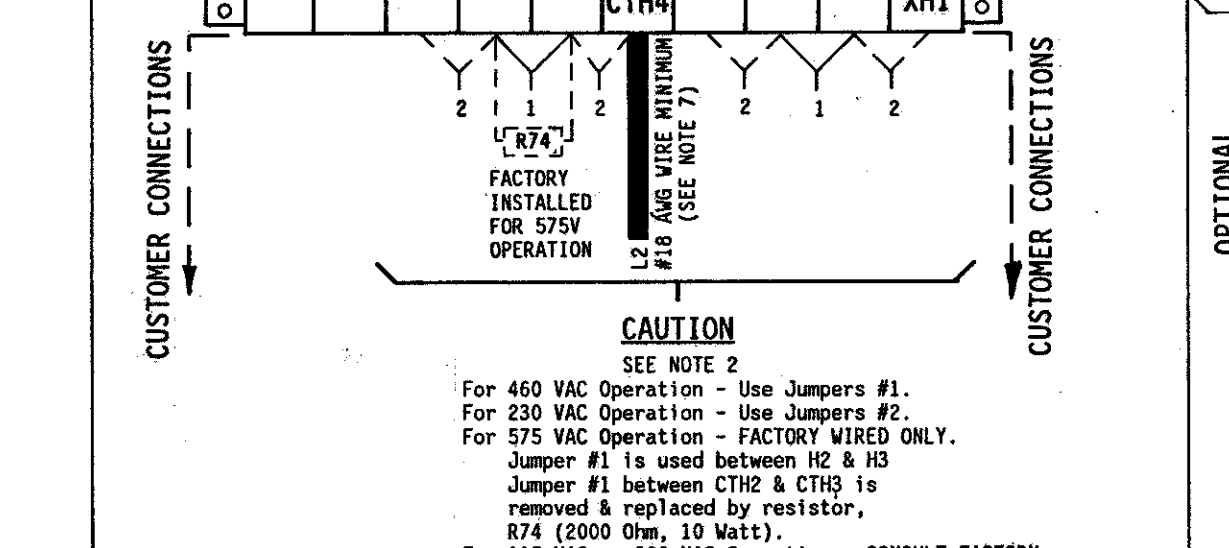

CAUTION - CONTROL WIRED FOR 460 VAC OPERATION - UNLESS OTHERWISE SPECIFIED.

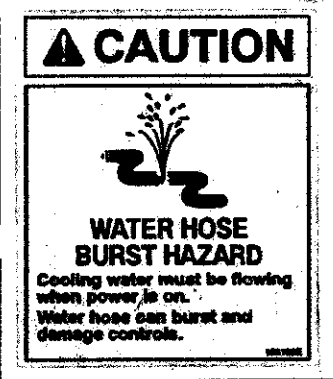
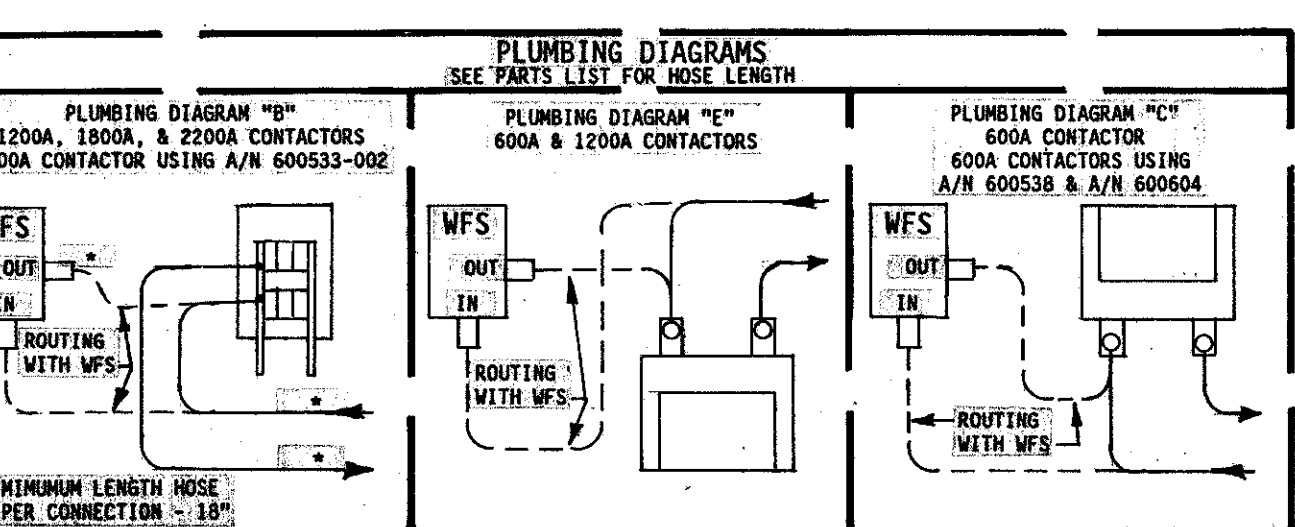
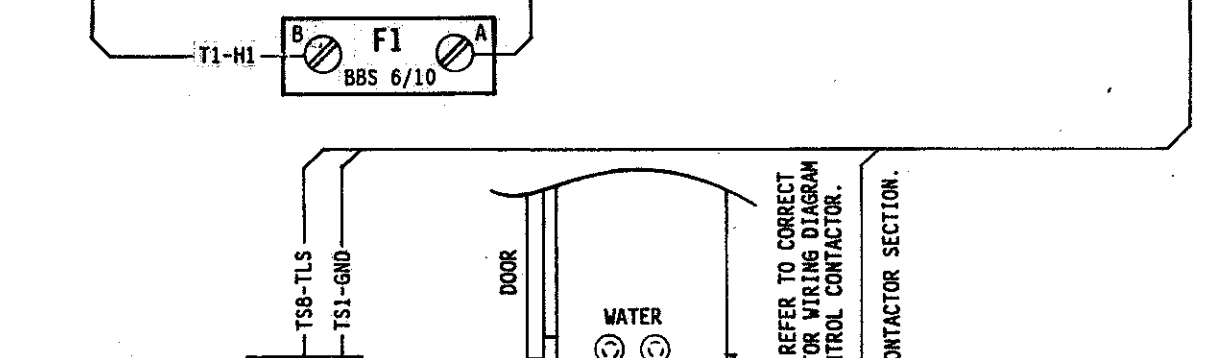

Table with 4 columns: REV, AUTH, DESCRIPTION, DATE. Lists revision history for the drawing.

Table with 4 columns: REV, AUTH, DESCRIPTION, DATE. Lists revision history for the drawing.

ENTRON CONTROLS INC. WIRING DIAGRAM, EN1380-SERIES, "D", "T", "LS", "LF", or "LF" CABINET. Includes scale, date, and drawing number information.