



WS700 to EN7000TS conversion guide

A guide to converting existing WS700 installations to use the EN7000TS control.



Document change record

15/4/20	Initial release

Table of Contents

Section	Page
1. Introduction.....	3
2. Mechanical considerations.....	3
2.1. Depth.....	3
2.2. Clearance.....	3
2.3. Aperture	3
3. Connection to the power system.....	4
3.1. No Entron power board present.....	4
3.1.1. Fit a new Entron power board.....	4
3.1.2. Fit an IDC adapter	4
3.2. Older type Entron power board fitted	4
3.3. Newer type Entron power board fitted	5
3.3.1. SCR thermal contact	5
4. Discrete Inputs and Outputs (I/O)	6
4.1. Inputs	6
4.2. Outputs.....	6
5. Current Transformer (CT).....	7
5.1. Reusing the original CT (ARW 800:1 type).....	7
5.2. Fitting a new type CT (ABB CTMAX1000)	7
5.3. Using other types of CT	7
6. Toroid	8
7. Proportional Valve (PV)	8
7.1. Output to proportional valve.....	8
7.2. Input from sensor	8
8. RS232 port.....	9
9. Sequencer.....	9

10.	Ethernet on EN7000TS	9
11.	Users connection diagrams	10
11.1.	WS700.....	10
11.2.	EN7000TS	10
12.	Typical wiring diagrams.....	11
12.1.	WS700.....	11
12.2.	EN7000TS	11
13.	Parts list	12

1. Introduction

The WS700 was first produced in 2002 but by 2018 it had become impossible to source suitable components. The EN7000TS was designed as a new control, but retains the form-factor of the WS700 and is suitable for use as a replacement in most instances.

This document is intended to act as a guide for users wishing to convert an existing WS700 installation to work with an EN7000TS. Where the document instructs obtaining a new part, see section 13 for a list of suitable parts available from Entron.

As each connection is discussed in detail, section by section, please also refer to the diagrams in section 11 and 12.

Although most common situations are covered here, please contact the factory if you require further assistance: contact details may be found on the last page.

2. Mechanical considerations

2.1. Depth

WS700 has a depth behind the panel of 38 mm. On EN7000TS, the depth is 49 or 58 mm, depending on which cover is fitted. Check that there is sufficient clearance behind the pane to accommodate the increased depth.

2.2. Clearance

EN7000TS has connections along the top edge (WS700 does not). Check that there is sufficient clearance for any connectors that you may wish to use.

2.3. Aperture

EN7000TS and WS700 require the same aperture. Disconnect all connectors to the WS700, remove the M4 nuts (2 down each side) holding the control in the panel, then remove the control from the front. Place the EN7000TS into the aperture and re-fit the M4 nuts.

3. Connection to the power system

On WS700, connection to the power system was via discrete wiring. ON EN7000TS, these connections are done via a 26-way ribbon cable. The method used for conversion will depend upon the original installation. There are three or more possibilities. In this section we refer to **Entron power boards**. These will bear the part number designation W293133 or W293144.

3.1. No Entron power board present

In this situation, there are two options:

3.1.1. Fit a new Entron power board

Obtain a latest version Entron power board (with the same part number), fit this to the system and proceed as in section 3.3.

OR

3.1.2. Fit an IDC adapter

An IDC adapter is a small unit which accepts discrete wiring on a terminal block and passes the connections to a ribbon cable connector. Obtain an IDC adapter and fit this in the system. Disconnect the wiring at P1 and P3 on the WS700 and reconnect to the IDC adapter according to the following tables:

WS700 P1 terminal	Function	IDC adapter terminal
1	24V supply	1,19*
2	0V	3,18*
-	SCR thermal	20,21**

* Connect these two terminals together.

** Connect these two terminals together if not used for SCR thermal contact (n/c).

WS700 P3 terminal	Function	IDC adapter terminal
5	Sync	9
6	Sync	10
7	SCR trigger +	22
8	SCR trigger -	23

Note: there may be other wiring to P1 and P3 – these connections are covered later in this document.

Obtain a 26-way ribbon cable assembly of suitable length and connect this between the IDC adapter and the EN7000TS.

3.2. Older type Entron power board fitted

Older issues of these boards do not have a ribbon cable connector (P2). Obtain the latest version of the board and use this to replace the older board. Proceed as in section 3.3.

3.3. Newer type Entron power board fitted

The latest versions of these boards already have a ribbon cable connector (P2) fitted and this is compatible with the EN7000TS. Remove the following connections from the WS700 P1 connector and reconnect to the power board as shown in the following table:

WS700 P1 terminal	Function	Power board P1 terminal
1	24V supply	6
2	0V	5

Remove all other connections between the power board and the WS700.

Obtain a 26-way ribbon cable assembly of suitable length and connect this between the power board and the EN7000TS.

3.3.1. SCR thermal contact

If the system has a (normally closed) thermal contact on the SCR then this should already be connected to the power board at connector X1 terminals 3 & 4. If so, then this need not be changed, otherwise connect the thermal contact as stated. If there is no thermal contact then link X1 terminals 3 & 4 together.

4. Discrete Inputs and Outputs (I/O)

Also see section 11.

4.1. Inputs

On WS700, discrete inputs are made at connector P2. On EN7000TS the input connector is designated X3. Not all connections may have been used.

Reconnect the WS700 signals as per the following table:

WS700 P2 terminal	Function	EN7000TS X3 terminal
1	Start	1
2	Weld on	2
3	2 nd stage	5
4	Retract	6
5	Reset fault	7
6	Reset counter/stepper ¹	8,9
7	Program select P1	10
8	Program select P2	11
9	Program select P4	12
10	Program select P8	13
11	Program select P16	14
12	Program select P32	15
13	Stop	3
14	Thermal	4
15	Not used	-
16	Edit disable	16

¹ On WS700 there is a single input for reset counter/stepper (P2.6). On EN7000TS there are separate inputs for **Reset counter** (X3.8) and **Reset stepper** (X3.9). These may be connected together if required.

The common side to the switches will be connected to the 24V supply. This may be left in place but if possible, reconnect to X3 pin 17 terminal on the EN7000TS.

4.2. Outputs

On WS700 discrete outputs are made at connector P1. On EN7000TS the output connector is designated X1. Not all connections may have been used.

Reconnect the WS700 signals as per the following table:

WS700 P1 terminal	Function	EN7000TS X1 terminal
1	24V supply input	See section 3.3
2	0V	See section 3.3
3	Not used	-
4	Ready	4
5	Contactors	5
6	Counter	6
7	Fault	3
8	EOS	1
9	HAV	2
10	WAV	16

The common side of the outputs will be connected to the 0V side of the power supply. This may be left in place or connected to X2 terminal 18 on the EN7000TS.

5. Current Transformer (CT)

A CT can be used to measure the welding current, normally on the primary side of the welding transformer.

5.1. Reusing the original CT (ARW 800:1 type)

Disconnect all wiring from the CT to the power board and/or control.

Connect a 2 Ohm resistor (a panel mounting 25-Watt type is a good choice) across the CT. This is important: failure to do so will certainly result in damage to the control.

Connect the CT to the EN7000TS at X4 terminals 1 & 2 (polarity is unimportant). Use a screened cable and connect the screen to X4 terminal 5.

Set the EN7000TS current calibration parameter *CT sensitivity* to 2500 mV/kA.

5.2. Fitting a new type CT (ABB CTMAX1000)

Disconnect all wiring from the old CT to the power board and/or control. To remove the old CT, you will have to temporarily disconnect one end of the cable which passes through it. Do not leave the old CT in situ as this is dangerous.

The new style CT should come complete with a 0.39 Ohm resistor fitted across the CT. This is important: do not operate without this resistor. Failure to do so will certainly result in damage to the control.

Connect the CT to the EN7000TS at X4 terminals 1 & 2 (polarity is unimportant). Use a screened cable and connect the screen to X4 terminal 5.

Set the EN7000TS current calibration parameter *CT sensitivity* to 1950 mV/kA.

5.3. Using other types of CT

Please consult the factory for advice. Contact details may be found on the last page.

6. Toroid

A Toroid (or Rogowski coil) can be used to measure the welding current. It is usually fitted to the secondary circuit of a welding machine or is sometimes built in to the welding transformer. If your system makes use of a toroid, reconnect as shown in the table below:

WS700 P3 terminal	Function	EN7000TS X4 terminal
1	Toroid	3
3	Toroid	4
4	Ground	5

7. Proportional Valve (PV)

7.1. Output to proportional valve

Reconnect the wiring to the PV as shown in the table below:

WS700 P3 terminal	Function	EN7000TS X5 terminal
12	Output 0..10V	2
13	0V	1
14	Ground	4

7.2. Input from sensor

Reconnect the wiring to the sensor as shown in the table below:

WS700 P3 terminal	Function	EN7000TS X5 terminal
9	Input 0..10V	3
10	0V	1
11	Ground	4

8. RS232 port

If used, remove the connector at P4 on the WS700 and reconnect at the RS232 port on the EN7000TS.

9. Sequencer

The WS700 contained a sequencer feature which could be used to perform small scale PLC-like logic functions. There is no corresponding feature in the EN7000TS. There are numerous micro-PLCs available which might be employed to fulfil this function.

10. Ethernet on EN7000TS

EN7000TS is equipped with an Ethernet port which may be used for connection to a network or directly to a PC. NetFlash programming software is available for your PC: this allows easy editing of all parameters in the EN7000 plus numerous other functions. Please consult the factory for details.

11. Users connection diagrams

11.1. WS700

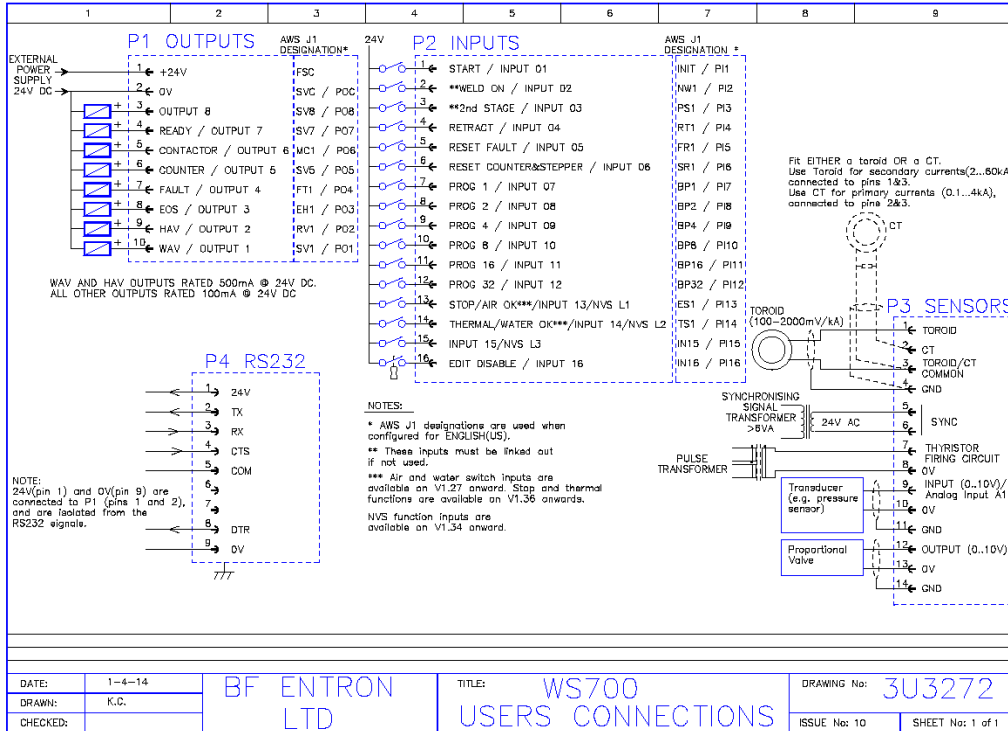

11.2. EN700TS

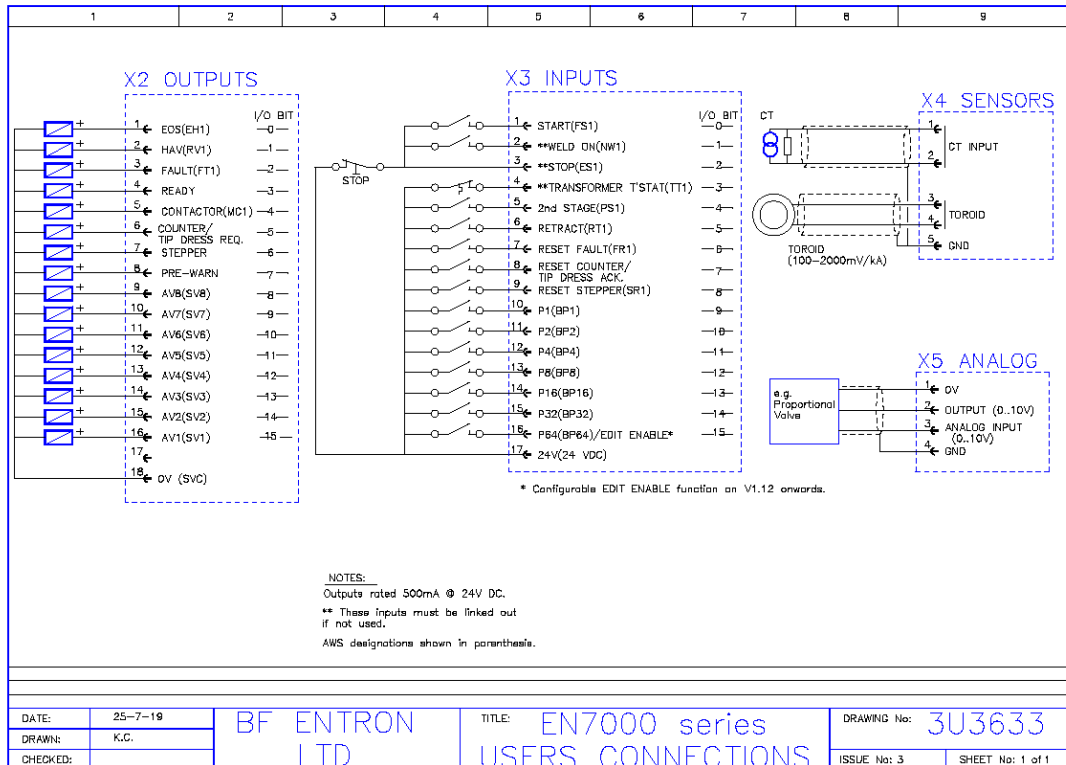

12. Typical wiring diagrams

12.1. WS700

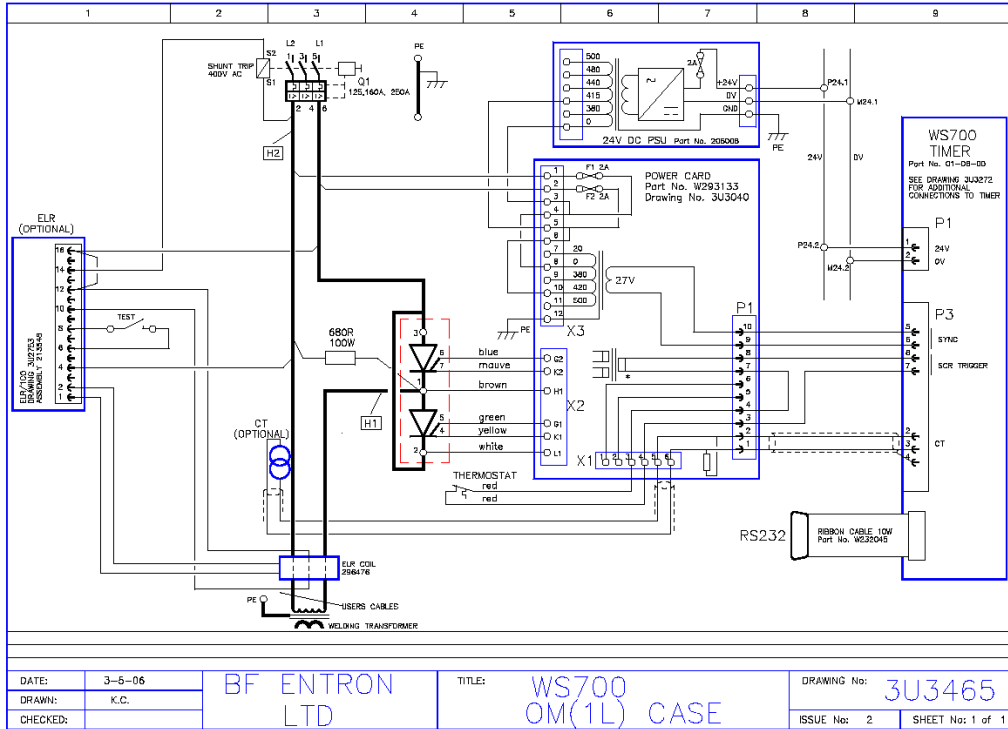

12.2. EN7000TS

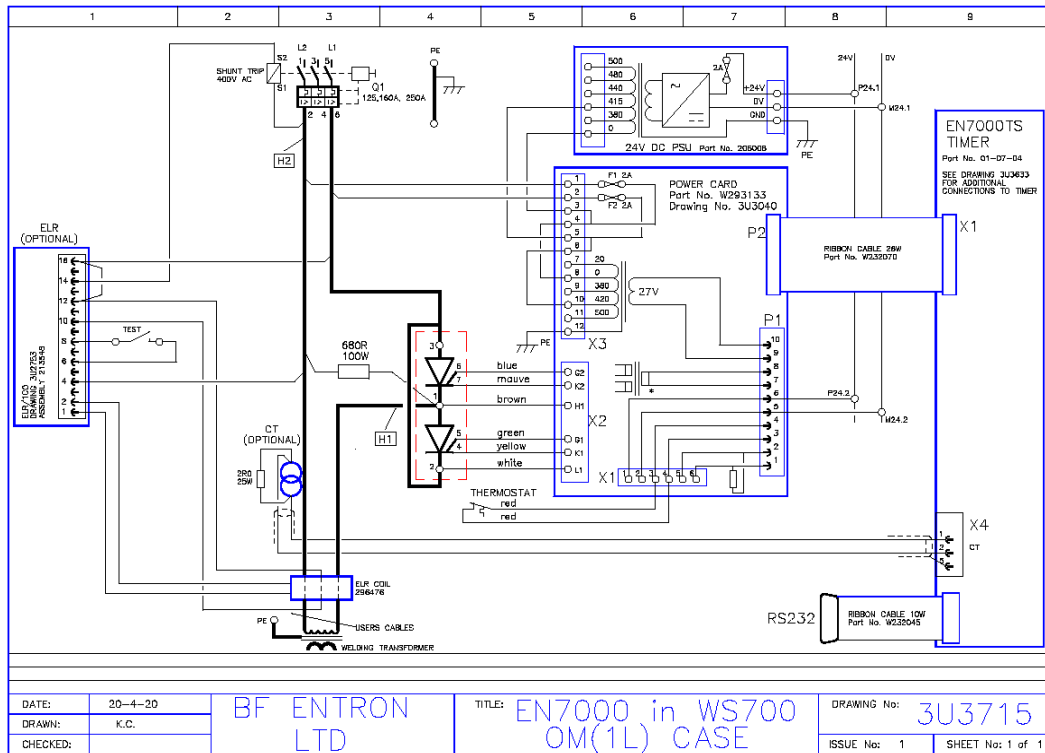

13. Parts list

The following table lists parts which are available from Entron to assist with the conversion. Depending upon the starting point you may need some or all of these parts.

Entron part number	Description
01-07-04	EN7000TS Welding control
W232070	26-way ribbon cable assembly
W293133	Power board (440V)
W293144	Power board (240V)
92-18-06-06	CT assembly
226109	26-way IDC adapter
90-90-90	NetFlash programming software for PC
220014	Door mounting RJ45 socket
202053	Cat 6 patch cable (0.9 m)

BF Entron Ltd. England.

Tel: +44 (0)1384 455401

Entron Controls LLC. USA.

Tel: 864-416-0190

Entron Controls De Mexico.

Tel: +52 (844) 415 9081

www.entroncontrols.com